

**GB**

**WAGNER®**

**Operating manual**

---

# **ProSpray 3.23**

## **Airless high-pressure spraying unit**

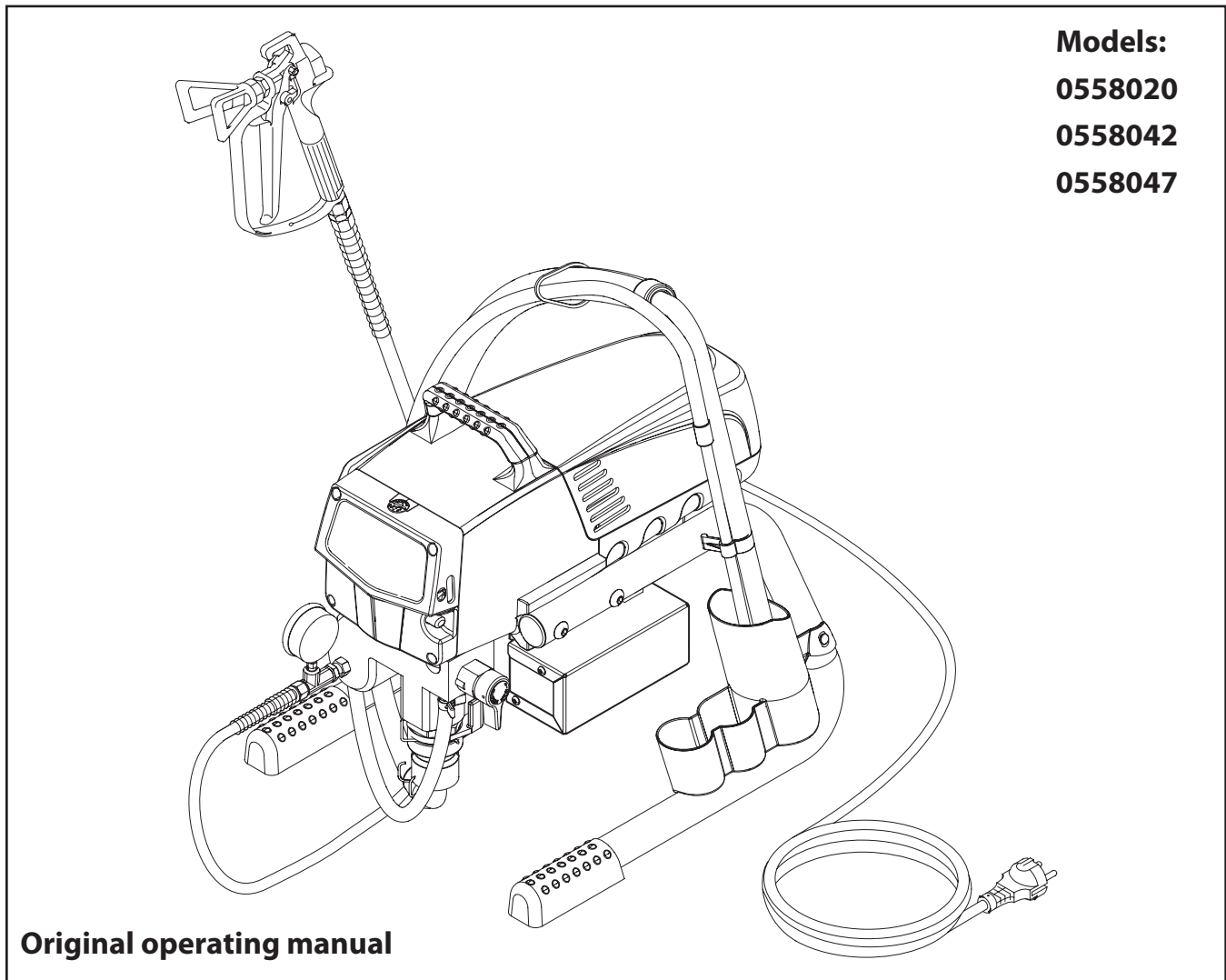

**ProSpray 3.23**

# Warning!

**Attention: Danger of injury by injection!**  
**Airless units develop extremely high spraying pressures.**

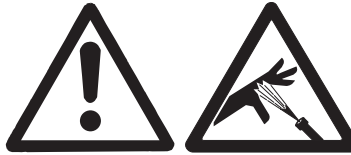
**1**

**Never put your fingers, hands or any other parts of the body into the spray jet!**

**Never point the spray gun at yourself, other persons or animals.**

**Never use the spray gun without safety guard.**

**Do not treat a spraying injury as a harmless cut. In case of injury to the skin through coating materials or solvents, consult a doctor immediately for quick and expert treatment. Inform the doctor about the coating material or solvent used.**

**2**

**The operating instructions state that the following points must always be observed before starting up:**

1. Faulty units must not be used.
2. Secure WAGNER spray gun using the safety catch on the trigger.
3. Ensure that the unit is properly earthed.
4. Check allowable operating pressure of high-pressure hose and spray gun.
5. Check all connections for leaks.

**3**

**The instructions regarding regular cleaning and maintenance of the unit must be strictly observed.**

**Before any work is done on the unit or for every break in work the following rules must be observed:**

1. Release the pressure from spray gun and hose.
2. Secure the WAGNER spray gun using the safety catch on the trigger.
3. Switch off unit.

# Be safety conscious!







## Contents

	Page		Page
<b>1. Safety regulations for Airless spraying</b> .....	4	<b>9. Remedy in case of faults</b> .....	13
1.1 Explanation of symbols used .....	4	<b>10. Servicing</b> .....	14
1.2 Electric Safety.....	5	10.1 General servicing.....	14
1.3 Electrostatic charging (formation of sparks or flames).....	5	10.2 High-pressure hose.....	14
<b>2. General view of application</b> .....	6	<b>11. Repairs at the unit</b> .....	14
2.1 Application .....	6	11.1 Relief valve.....	14
2.2 Coating materials .....	6	11.2 Inlet and outlet valve .....	14
<b>3. Description of unit</b> .....	6	11.3 Packings.....	15
3.1 Airless process .....	6	11.4 ProSpray 3.23 connection diagram .....	16
3.2 Functioning of the unit .....	6	<b>12. Appendix</b> .....	17
3.3 Legend for explanatory diagram ProSpray 3.23 .....	7	12.1 Selection of tip .....	17
3.4 Explanatory diagram ProSpray 3.23 .....	7	12.2 Servicing and cleaning of Airless hard-metal tips .....	17
3.5 Technical data .....	8	12.3 Spray gun accessories.....	17
3.6 Transportation in vehicle.....	8	12.4 Airless tip table.....	18/19
<b>4. Starting operation</b> .....	8	12.5 Pump-Runner .....	20
4.1 High-pressure hose, spray gun and separating oil .....	8	<b>Sales and service companies</b> .....	21
4.2 Control panel indicators .....	9	<b>Accessories for ProSpray 3.23</b> .....	22
4.3 Pressure control knob settings.....	9	<b>Spare parts list for main assembly</b> .....	24
4.4 Connection to the mains network .....	9	<b>Spare parts list for fluid section</b> .....	26
4.5 Cleaning preserving agent when starting-up of operation initially.....	10	<b>Spare parts list for drive assembly</b> .....	28
4.6 Taking the unit into operation with coating material.....	10	<b>Spare parts list of frame</b> .....	30
<b>5. Spraying technique</b> .....	10	<b>Spare parts list for suction system</b> .....	31
<b>6. Handling the high-pressure hose</b> .....	11	<b>Important notes on product liability</b> .....	32
<b>7. Interruption of work</b> .....	11	<b>3+2 years guarantee for professional finishing</b> .....	32
<b>8. Cleaning the unit (shutting down)</b> .....	11		
8.1 Cleaning unit from outside.....	11		
8.2 Suction filter .....	12		
8.3 Cleaning the high-pressure filter.....	12		
8.4 Cleaning Airless spray gun.....	12		

# 1. Safety regulations for Airless spraying

## 1.1 Explanation of symbols used

This manual contains information that must be read and understood before using the equipment. When you come to an area that has one of the following symbols, pay particular attention and make certain to heed the safeguard.

	<b>This symbol indicates a potential hazard that may cause serious injury or loss of life. Important safety information will follow.</b>
	<b>This symbol indicates a potential hazard to you or to the equipment. Important information that tells how to prevent damage to the equipment or how to avoid causes of minor injuries will follow.</b>
	<b>Danger of skin injection</b>
	<b>Danger of fire from solvent and paint fumes</b>
	<b>Danger of explosion from solvent, paint fumes and incompatible materials</b>
	<b>Danger of injury from inhalation of harmful vapors</b>
	<b>Notes give important information which should be given special attention.</b>



### HAZARD: INJECTION INJURY

**Attention: Danger of injury by injection! A high pressure stream produced by this equipment can pierce the skin and underlying tissues, leading to serious injury and possible amputation.**

**Do not treat a spraying injury as a harmless cut. In case of injury to the skin through coating materials or solvents, consult a doctor immediately for quick and expert treatment. Inform the doctor about the coating material or solvent used.**

#### PREVENTION:

- NEVER aim the gun at any part of the body.
- NEVER allow any part of the body to touch the fluid stream. DO NOT allow body to touch a leak in the fluid hose.
- NEVER put your hand in front of the gun. Gloves will not provide protection against an injection injury.
- ALWAYS lock the gun trigger, shut the fluid pump off and release all pressure before servicing, cleaning the tip guard, changing tips, or leaving unattended. Pressure will not be released by turning off the engine. The PRIME/SPRAY valve or pressure bleed valve must be turned to their appropriate positions to relieve system pressure.
- ALWAYS keep tip guard in place while spraying. The tip guard provides some protection but is mainly a warning device.
- ALWAYS remove the spray tip before flushing or cleaning the system.
- NEVER use a spray gun without a working trigger lock and trigger guard in place.

- All accessories must be rated at or above the maximum operating pressure range of the sprayer. This includes spray tips, guns, extensions, and hose.



### HAZARD: HIGH PRESSURE HOSE

**The paint hose can develop leaks from wear, kinking and abuse. A leak can inject material into the skin. Inspect the hose before each use.**

#### PREVENTION:

- High-pressure hoses must be checked thoroughly before they are used.
- Replace any damaged high-pressure hose immediately.
- Never repair defective high-pressure hoses yourself!
- Avoid sharp bends and folds: the smallest bending radius is about 20 cm.
- Do not drive over the high-pressure hose. Protect against sharp objects and edges.
- Never pull on the high-pressure hose to move the device.
- Do not twist the high-pressure hose.
- Do not put the high-pressure hose into solvents. Use only a wet cloth to wipe down the outside of the hose.
- Lay the high-pressure hose in such a way as to ensure that it cannot be tripped over.



**Only use WAGNER original-high-pressure hoses in order to ensure functionality, safety and durability.**



### HAZARD: EXPLOSION OR FIRE

**Solvent and paint fumes can explode or ignite. Severe injury and/or property damage can occur.**

#### PREVENTION:

- Do not use materials with a flashpoint below 21° C (70° F). Flashpoint is the temperature at which a fluid can produce enough vapors to ignite.
- Do not use the unit in work places which are covered by the explosion protection regulations.
- Provide extensive exhaust and fresh air introduction to keep the air within the spray area free from accumulation of flammable vapors.
- Avoid all ignition sources such as static electricity sparks, electrical appliances, flames, pilot lights, hot objects, and sparks from connecting and disconnecting power cords or working light switches.
- Do not smoke in spray area.
- Place sprayer sufficient distance from the spray object in a well ventilated area (add more hose if necessary). Flammable vapors are often heavier than air. Floor area must be extremely well ventilated. The pump contains arcing parts that emit sparks and can ignite vapors.
- The equipment and objects in and around the spray area must be properly grounded to prevent static sparks.
- Use only conductive or earthed high pressure fluid hose. Gun must be earthed through hose connections.
- Power cord must be connected to a grounded circuit (electric units only).
- Always flush unit into separate metal container, at low pump pressure, with spray tip removed. Hold gun firmly against side of container to ground container and prevent static sparks.

- Follow material and solvent manufacturer's warnings and instructions. Be familiar with the coating material's MSDS sheet and technical information to ensure safe use.
- Use lowest possible pressure to flush equipment.
- When cleaning the unit with solvents, the solvent should never be sprayed or pumped back into a container with a small opening (bunghole). An explosive gas/air mixture can arise. The container must be earthed.



### HAZARD: HAZARDOUS VAPORS

Paints, solvents, and other materials can be harmful if inhaled or come in contact with body. Vapors can cause severe nausea, fainting, or poisoning.

#### PREVENTION:

- Wear respiratory protection when spraying. Read all instructions supplied with the mask to be sure it will provide the necessary protection.
- All local regulations regarding protection against hazardous vapors must be observed.
- Wear protective eyewear.
- Protective clothing, gloves and possibly skin protection cream are necessary for the protection of the skin. Observe the regulations of the manufacturer concerning coating materials, solvents and cleaning agents in preparation, processing and cleaning units.



### HAZARD: GENERAL

This product can cause severe injury or property damage.

#### PREVENTION:

- Follow all appropriate local, state, and national codes governing ventilation, fire prevention, and operation.
- Pulling the trigger causes a recoil force to the hand that is holding the spray gun. The recoil force of the spray gun is particularly powerful when the tip has been removed and a high pressure has been set on the airless pump. When cleaning without a spray tip, set the pressure control knob to the lowest pressure.
- Use only manufacturer authorized parts. User assumes all risks and liabilities when using parts that do not meet the minimum specifications and safety devices of the pump manufacturer.
- ALWAYS follow the material manufacturer's instructions for safe handling of paint and solvents.
- Clean up all material and solvent spills immediately to prevent slip hazard.
- Wear ear protection. This unit can produce noise levels above 85 dB(A).
- Never leave this equipment unattended. Keep away from children or anyone not familiar with the operation of airless equipment.
- Do not spray on windy days.
- The device and all related liquids (i.e. hydraulic oil) must be disposed of in an environmentally friendly way.

## 1.2 Electric Safety

Electric models must be earthed. In the event of an electrical short circuit, earthing reduces the risk of electric shock by providing an escape wire for the electric current. This product is equipped with a cord having an earthing wire with an appropriate earthing plug. Connection to the mains only through a special feed point, e.g. through an error protection installation with INF < 30 mA.



**DANGER — Work or repairs at the electrical equipment may only be carried out by a skilled electrician. No liability is assumed for incorrect installation. Switch the unit off. Before all repair work, unplug the power plug from the outlet.**

Danger of short-circuits caused by water ingressing into the electrical equipment. Never spray down the unit with high-pressure or high-pressure steam cleaners.

#### Work or repairs at the electrical equipment:

These may only be carried out by a skilled electrician. No liability is assumed for incorrect installation.

## 1.3 Electrostatic charging (formation of sparks or flames)































**Electrostatic charging of the unit may occur during spraying due to the flow speed of the coating material. These can cause sparks and flames upon discharge. The unit must therefore always be earthed via the electrical system. The unit must be connected to an appropriately-grounded safety outlet.**

An electrostatic charging of spray guns and the high-pressure hose is discharged through the high-pressure hose. For this reason the electric resistance between the connections of the high-pressure hose must be equal to or lower than 1 MΩ.

## 2. General view of application

### 2.1 Application

 = Recommended  = Not-recommended

Materials	Object Size	Model						
		PS 3.21	PS 3.23	PS 3.25	PS 3.29	PS 3.31	PS 3.34	PS 3.39
Release agents, oils, undercoats, primers, fillers, synthetic resin-based paints, acrylic paints recommended nozzle size: FineFinish 0.008" - 0.014"	up to 200 m <sup>2</sup> 200 m <sup>2</sup> - 800 m <sup>2</sup> more than 800 m <sup>2</sup>							
Emulsion paints, latex paints recommended nozzle size: 0.017" - 0.027"	up to 200 m <sup>2</sup> 200 m <sup>2</sup> - 800 m <sup>2</sup> more than 800 m <sup>2</sup>							
Anti-corrosive agents, flame retardants, fabric adhesive recommended nozzle size: 0.021" - 0.031"	up to 200 m <sup>2</sup> 200 m <sup>2</sup> - 800 m <sup>2</sup> more than 800 m <sup>2</sup>							
Airless-scrappers recommended nozzle size: 0.027" - 0.039"	up to 200 m <sup>2</sup> 200 m <sup>2</sup> - 800 m <sup>2</sup> more than 800 m <sup>2</sup>							

### 2.2 Coating materials

#### Processible coating materials



**Pay attention to the Airless quality of the coating materials to be processed.**

Dilutable lacquers and paints or those containing solvents, two-component coating materials, dispersions, latex paints.

No other materials should be used for spraying without WAGNER's approval.

#### Filtering

Despite suction filter and insertion filter in the spray gun, filtering of the coating material is generally advisable.

Stir coating material before commencement of work.



**Attention: Make sure, when stirring up with motor-driven agitators that no air bubbles are stirred in. Air bubbles disturb when spraying and can, in fact, lead to interruption of operation.**

#### Viscosity

With this unit it is possible to process highly viscous coating materials of up to around 20.000 MPa·s.

If highly viscous coating materials cannot be taken in by suction, they must be diluted in accordance with the manufacturer's instructions.

#### Two-component coating material

The appropriate processing time must be adhered to exactly. Within this time rinse through and clean the unit meticulously with the appropriate cleaning materials.

#### Coating materials with sharp-edged additional materials

These have a strong wear and tear effect on valves, high-pressure hose, spray gun and tip. The durability of these parts can be reduced appreciably through this.

## 3. Description of unit

### 3.1 Airless process

The main areas of application are thick layers of highly viscous coating material for large areas and a high consumption of material. A piston pump takes in the coating material by suction and conveys it to the tip. Pressed through the tip at a pressure of up to a maximum of 221 bar (22,1 MPa), the coating material is atomised. This high pressure has the effect of micro fine atomisation of the coating material.

As no air is used in this process, it is described as an AIRLESS process.

This method of spraying has the advantages of finest atomisation, cloudless operation and a smooth, bubble-free surface. As well as these, the advantages of the speed of work and convenience must be mentioned.

### 3.2 Functioning of the unit

In the following there is a short description of the technical construction for better understanding of the function.

WAGNER ProSpray units are electrically driven high-pressure spraying units.

A gear unit transfers the driving force to a crankshaft. The crankshaft moves the pistons of the material feed pump up and down.

The inlet valve is opened automatically by the upwards movement of the piston. The outlet valve is opened when the piston moves downward.

The coating material flows under high pressure through the high-pressure hose to the spray gun. When the coating material exits from the tip it atomizes.

The pressure regulator controls the volume and the operating pressure of the coating material.

### 3.3 Legend for explanatory diagram ProSpray 3.23

- |                      |  |
|----------------------|--|
| 1 Spray gun          | 9 Oil button   |
| 2 High-pressure hose | 10 Oil level gauge   |
| 3 Return hose        | 11 ON/OFF switch   |
| 4 Suction hose       | 12 Control panel indicators  |
| 5 Frame              | 13 Pressure control knob   |
| 6 Drip cup           | 14 Oil cup for EasyGlide (EasyGlide prevents increased wear of the packings) |
| 7 Power cord         | 15 Pusher stem   |
| 8 Relief valve       | 16 Manometer   |
- Lever position vertical – PRIME (↻ circulation)  
 Lever position horizontal – SPRAY (↻)

### 3.4 Explanatory diagram ProSpray 3.23

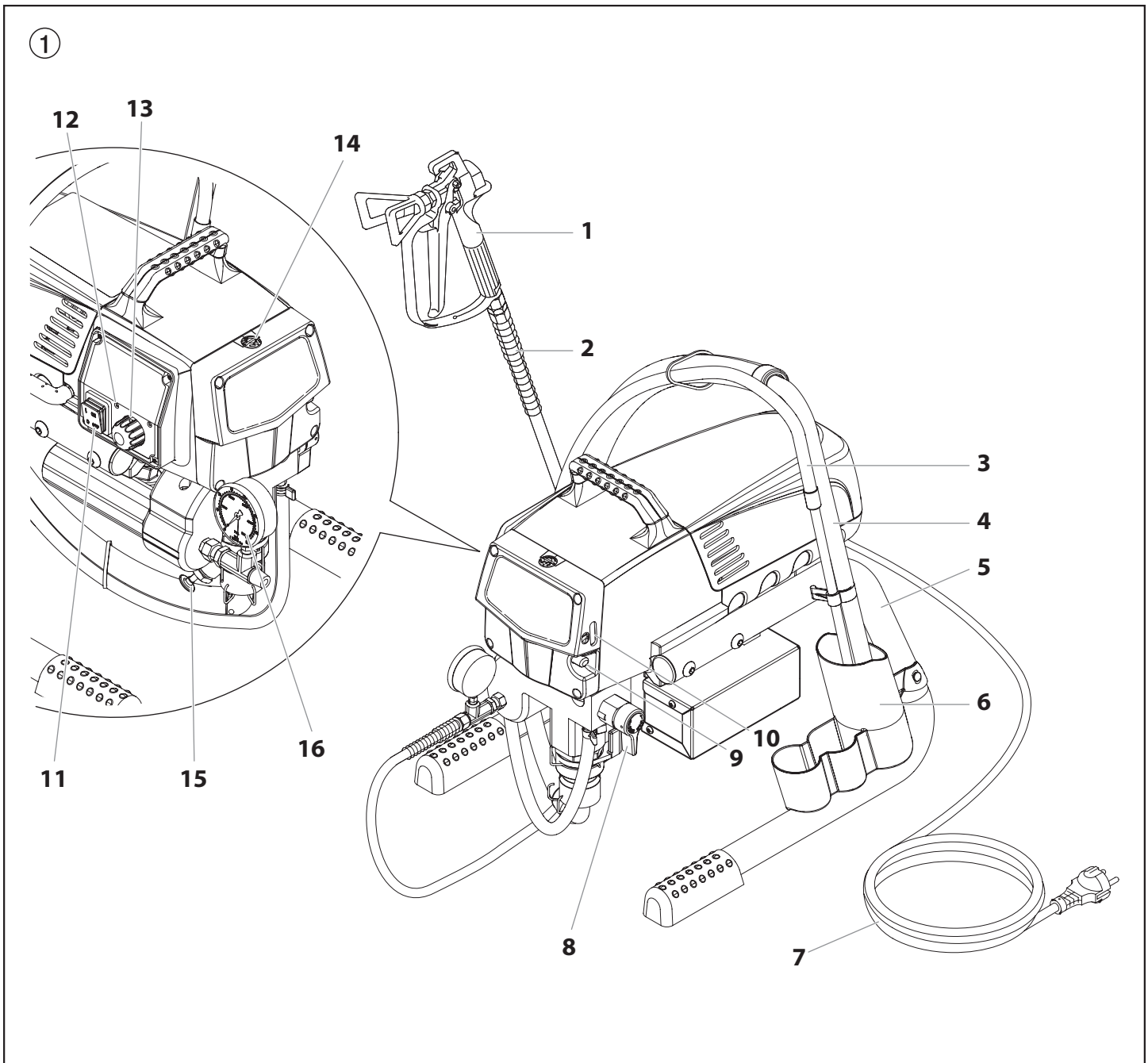

### 3.5 Technical data

<b>Voltage:</b>	100-110 Volt , 50/60 Hz
<b>Max. current consumption:</b>	11 A
<b>Power cord:</b>	3 x 1.5 mm <sup>2</sup> – 6 m or 2.5 m
<b>Acceptance capacity:</b>	1035 Watt
<b>Max. operating pressure:</b>	221 bar (22.1 MPa)
<b>Volume flow at 12 MPa (120 bar) with water:</b>	2.3 l/min
<b>Max tip size:</b>	0.024 inch – 0.61 mm
<b>Max. temperature of the coating material:</b>	43°C
<b>Max viscosity:</b>	20.000 mPa·s
<b>Weight:</b>	17.7 kg
<b>Special high-pressure hose:</b>	DN 6 mm, 15 m, connection thread M 16 x 1.5
<b>Dimensions (L X W X H):</b>	436 x 369 x 416 mm
<b>Max sound pressure level:</b>	80 dB (A) *

\* Place of measuring: 1 m in distance from the unit and 1.6 m above the floor, 12 MPa (120 bar) operating pressure, reverberant floor.

### 3.6 Transportation in vehicle

Secure the unit with a suitable fastening.

## 4. Starting operation

### 4.1 High-pressure hose, spray gun and separating oil

1. Screw the pressure gauge (1) to the coating material outlet (Fig. 2, Item 2).
2. Screw the high-pressure hose (3) to the coating material outlet on the pressure gauge (Fig. 2, Item 4).
3. Screw the spray gun (5) with the selected tip onto the high-pressure hose.
4. Tighten the union nuts at the high-pressure hoses firmly so that coating material does not leak.

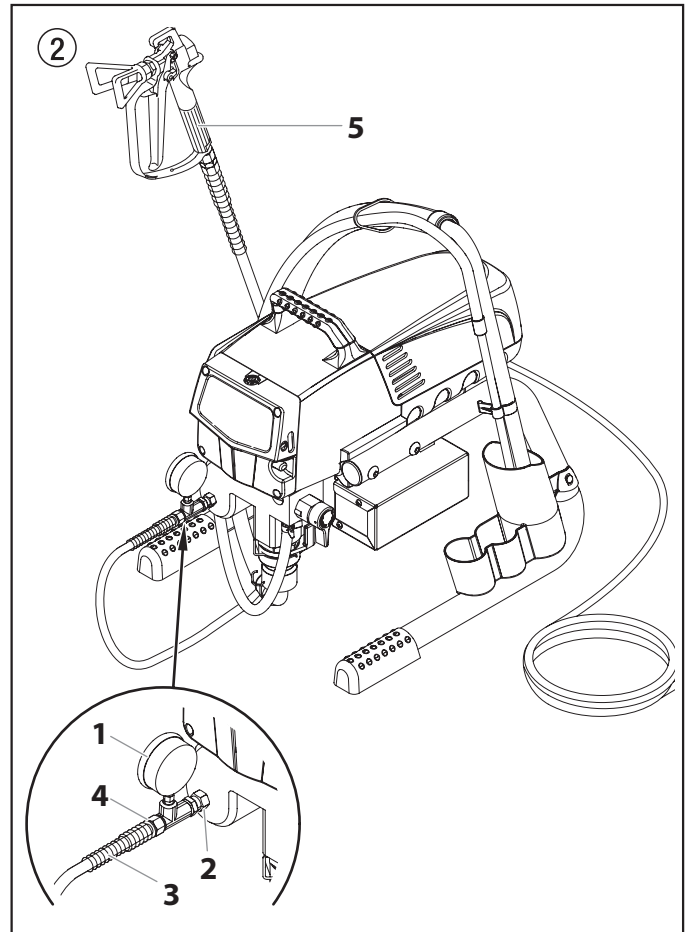

5. Remove the oil cup cap with a straight-slot screwdriver.
6. Fill the oil cup with EasyGlide (Fig. 3) until the oil gauge (6) is showing that it is full.



Attention

**EasyGlide prevents increased wear and tear to the packings.**

7. Replace oil cup cap.
8. Press oil button 2-5 times to prime the oiler. Press once for every eight hours of usage to lubricate the fluid section.
9. Fully depress the pusher stem to make sure the inlet ball is free.



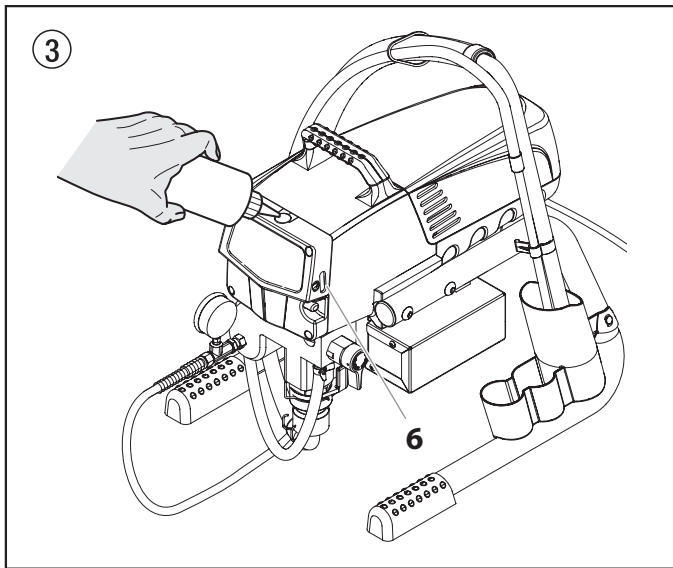

**Solid Green**

When the pressure indicator is solid green, the sprayer is operating between 12 MPa (120 bar) and 23 MPa (230 bar). A solid green pressure indicator means:

- The sprayer is at the proper pressure setting for spraying oil-based and latex house paints
- The sprayer is operating at peak performance at a high pressure setting
- If the pressure indicator goes to solid yellow when the pressure is set so that it starts at solid green, it indicates one of the following:
  - a. **Tip Wear Indicator** — when spraying with latex or at high pressure the solid yellow appears. This means the tip is worn and needs to be replaced.
  - b. **Tip Too Large** — when a tip that is too large for the sprayer is put in the gun, the pressure indicator will turn from solid green to solid yellow.
  - c. **Fluid Section Wear** — if a solid yellow pressure indicator appears when using a new tip and the pressure is set at maximum, service may be required (worn packings, worn piston, stuck valve, etc...).

**Service Indicator**

The Service indicator is on when the motor is commanded to run. This indicator is used by service centers to troubleshoot motor problems.

**4.3 Pressure control knob settings (Fig. 5)**

1. Minimum pressure setting
2. Black zone – no pressure generation
3. Blue zone – pulsating pressure for cleaning

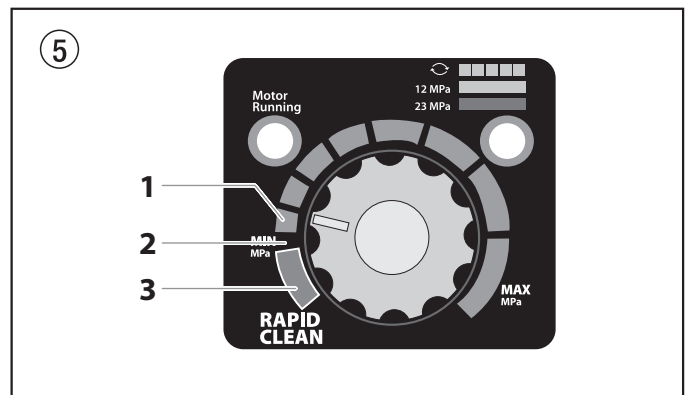

**4.4 Connection to the mains network**



**The unit must be connected to an appropriately-grounded safety outlet.**

Before connecting the unit to the mains supply, ensure that the line voltage matches that specified on the unit's rating plate. The connection must be equipped with a residual current protective device with INF ≤ 30 mA.

**4.2 Control Panel Indicators**

The following is a description of the control panel indicators.

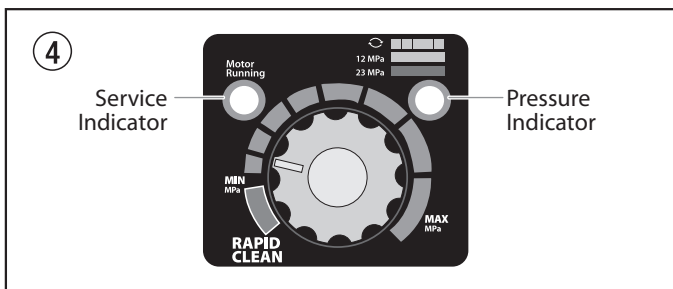

**Pressure Indicator**

The pressure indicator shows the current operating pressure of the sprayer. It has three different indications: blinking yellow, solid yellow, and solid green.

**Blinking Yellow**

When the pressure indicator is blinking yellow, the sprayer is operating between 0 and 1.4 MPa (14 bar). A blinking yellow pressure indicator means:

- The sprayer is plugged in and turned "ON"
- The sprayer is at priming pressure (little or no pressure)
- It is safe to move the relief valve between positions
- It is safe to change or replace the spray tip



**If the pressure indicator begins blinking yellow when the pressure control knob is set at a higher pressure and the relief valve is in the SPRAY position, either the spray tip is worn or the sprayer is in need of service/repair.**

**Solid Yellow**

When the pressure indicator is solid yellow, the sprayer is operating between 1.4 MPa (14 bar) and 12 MPa (120 bar). A solid yellow pressure indicator means:

- The sprayer is at the proper pressure setting for spraying stain, lacquer, varnish, and multi-colors

#### 4.5 Cleaning preserving agent when starting-up of operation initially

1. Immerse the suction tube (Fig. 6, Item 1) and return hose (2) into a container with a suitable cleaning agent.
2. Turn the pressure control knob counterclockwise (3) to minimum pressure.
3. Open the relief valve (4), valve position PRIME (↻ circulation).
4. Switch the unit (5) ON.
5. Wait until the cleaning agent exudes from the return hose.
6. Close the relief valve, valve position SPRAY (→ spray).
7. Pull the trigger of the spray gun.
8. Spray the cleaning agent from the unit into an open collecting container.

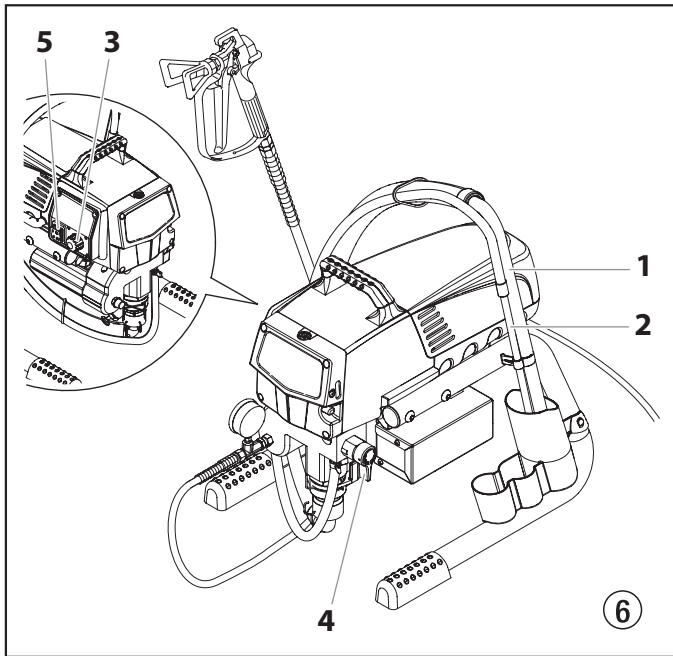

#### 4.6 Taking the unit into operation with coating material

1. Immerse the suction tube (Fig. 6, Item 1) and return hose (2) into the coating material container.
2. Turn the pressure control knob counterclockwise (3) to minimum pressure.
3. Open the relief valve (4), valve position PRIME (↻ circulation).
4. Switch the unit (5) ON.
5. Wait until the coating material exudes from the return hose.
6. Close the relief valve, valve position SPRAY (→ spray).
7. Trigger the spray gun several times and spray into a collecting container until the coating material exits the spray gun without interruption.
8. Increase the pressure by slowly turning up the pressure control knob.  
Check the spray pattern and increase the pressure until the atomization is correct.  
Always turn the pressure control knob to the lowest setting with good atomization.
9. The unit is ready to spray.

#### 5. Spraying technique



**Injection hazard. Do not spray without the tip guard in place. NEVER trigger the gun unless the tip is completely turned to either the spray or the unclog position. ALWAYS engage the gun trigger lock before removing, replacing or cleaning tip.**

The key to a good paint job is an even coating over the entire surface. Keep your arm moving at a constant speed and keep the spray gun at a constant distance from the surface. The best spraying distance is 25 to 30 cm between the spray tip and the surface.

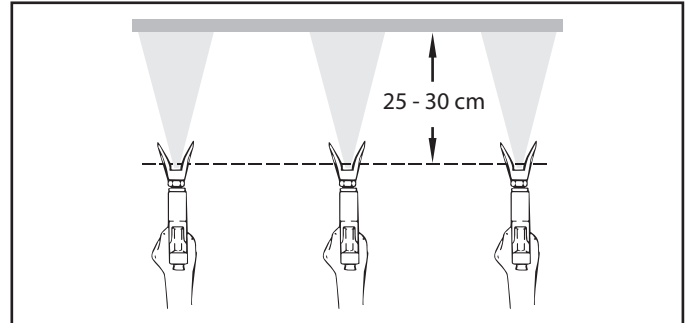

Keep the spray gun at right angles to the surface. This means moving your entire arm back and forth rather than just flexing your wrist.

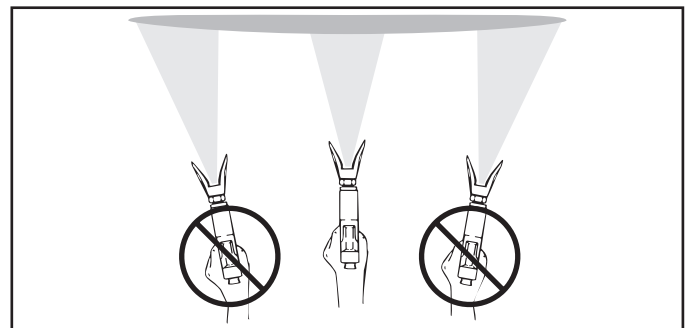

Keep the spray gun perpendicular to the surface, otherwise one end of the pattern will be thicker than the other.

Trigger gun after starting the stroke. Release the trigger before ending the stroke. The spray gun should be moving when the trigger is pulled and released. Overlap each stroke by about 30%. This will ensure an even coating.

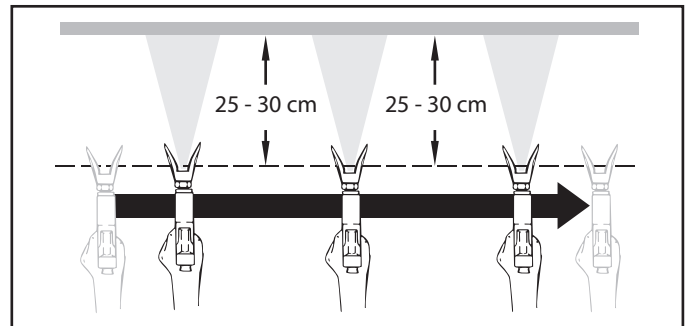

**If very sharp edges result or if there are streaks in the spray jet – increase the operating pressure or dilute the coating material.**

## 6. Handling the high-pressure hose

The unit is equipped with a high-pressure hose specially suited for piston pumps.



**Danger of injury through leaking high-pressure hose. Replace any damaged high-pressure hose immediately.**

**Never repair defective high-pressure hoses yourself!**

The high-pressure hose is to be handled with care. Avoid sharp bends and folds: the smallest bending radius is about 20 cm.

Do not drive over the high-pressure hose. Protect against sharp objects and edges.

Never pull on the high-pressure hose to move the device.

Make sure that the high-pressure hose cannot twist. This can be avoided by using a Wagner spray gun with a swivel joint and a hose system.



**When using the high-pressure hose while working on scaffolding, it is best to always guide the hose along the outside of the scaffolding.**



**The risk of damage rises with the age of the high-pressure hose. Wagner recommends replacing high-pressure hoses after 6 years.**



**Use only WAGNER original-high-pressure hoses in order to ensure functionality, safety and durability.**

## 7. Interruption of work

1. Open the relief valve, valve position PRIME (↻ circulation).
2. Switch the unit OFF.
3. Turn the pressure control knob counterclockwise to minimum pressure.
4. Pull the trigger of the spray gun in order to release the pressure from the high-pressure hose and spray gun.
5. Secure the spray gun, refer to the operating manual of the spray gun.
6. If a standard tip is to be cleaned, see Page 17, Section 12.2. If a non-standard tip is installed, proceed according to the relevant operating manual.
7. Depending on the model, leave the suction tube or the suction hose and return hose immersed in the coating material or swivel or immerse it into a corresponding cleaning agent.



Attention

**If fast-drying or two-component coating material is used, ensure that the unit is rinsed with a suitable cleaning agent within the processing time.**

## 8. Cleaning the unit (shutting down)

A clean state is the best method of ensuring operation without problems. After you have finished spraying, clean the unit. Under no circumstances may any remaining coating material dry and harden in the unit.

The cleaning agent used for cleaning (only with an ignition point above 21 °C) must be suitable for the coating material used.

- **Secure the spray gun**, refer to the operating manual of the spray gun.

Clean and remove tip.

For a standard tip, refer to Page 17, Section 12.2.

If a non-standard tip is installed, proceed according to the relevant operating manual.

1. Remove suction hose from the coating material.
2. Close the relief valve, valve position SPRAY (↗ spray).
3. Switch the unit ON.
4. Pull the trigger of the spray gun in order to pump the remaining coating material from the suction hose, high-pressure hose and the spray gun into an open container.



Attention

**The container must be earthed in case of coating materials which contain solvents.**



**Caution! Do not pump or spray into a container with a small opening (bunghole)! Refer to the safety regulations.**

5. Immerse suction hose with return hose into a container with a suitable cleaning agent.
6. Turn the pressure control knob into the blue zone - pulsating pressure for unit cleaning.
7. Open the relief valve, valve position PRIME (↻ circulation).
8. Pump a suitable cleaning agent in the circuit for a few minutes.
9. Close the relief valve, valve position SPRAY (↗ spray).
10. Pull the trigger of the spray gun.
11. Pump the remaining cleaning agent into an open container until the unit is empty.
12. Switch the unit OFF.

### 8.1 Cleaning unit from outside



Attention

**First of all pull out mains plug from socket.**



Attention

**Danger of short circuit through penetrating water! Never spray down the unit with high-pressure or high-pressure steam cleaners.**



Attention

**Do not put the high-pressure hose into solvents. Use only a wet cloth to wipe down the outside of the hose.**

Wipe down unit externally with a cloth which has been immersed in a suitable cleaning agent.

## 8.2 Suction filter



**A clean suction filter always guarantees maximum feed quantity, constant spraying pressure and problem-free functioning of the unit.**

1. Screw off the filter (Fig. 7) from suction pipe.
2. Clean or replace the filter.

Carry out cleaning with a hard brush and an appropriate cleaning agent.

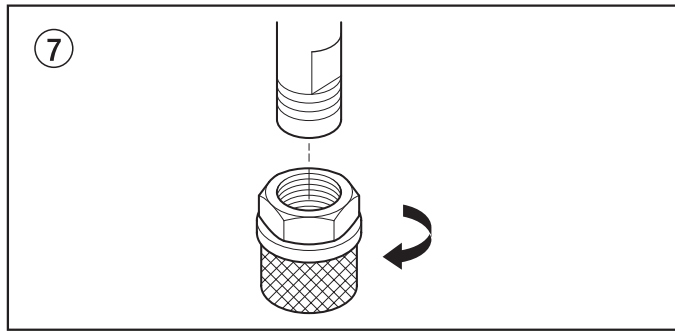

## 8.3 Cleaning the high-pressure filter

Clean the filter cartridge regularly.

A soiled or clogged high-pressure filter can cause a poor spray pattern or a clogged tip.

1. Turn the pressure control knob counterclockwise to minimum pressure.
2. Open the relief valve, valve position PRIME (↻ circulation).
3. Switch the unit OFF.



**Unplug the power plug from the outlet.**

4. Unscrew the filter housing (Fig. 8, Item 1). with a strap wrench.
5. Pull the filter cartridge (2) from the bearing spring (3).
6. Clean all the parts with the corresponding cleaning agent. If necessary, replace the filter cartridge.
7. Check the O-ring (4), replace it if necessary.
8. Place the bearing ring (5) against the bearing spring (3). Slide the filter cartridge (2) over the bearing spring.
9. Screw in filter housing (1) and tighten it as far as possible with the strap wrench.

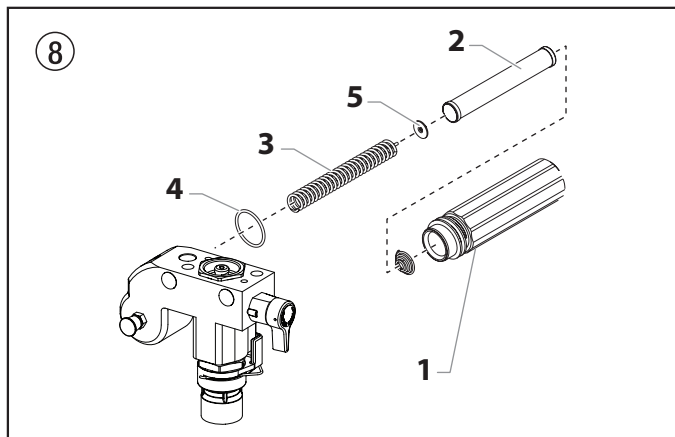

## 8.4 Cleaning Airless spray gun

1. Rinse Airless spray gun with an appropriate cleaning agent.
2. Clean tip thoroughly with appropriate cleaning agent so that no coating material residue remains.
3. Thoroughly clean the outside of the Airless spray gun.

### Intake filter in Airless spray gun

#### Disassembly (Fig. 9)

1. Pull protective guard (1) forward vigorously.
2. Screw grip (2) out of the gun housing. Remove intake filter (3).
3. Intake filter congested or defective – replace.

#### Assembly

1. Place intake filter (3) with the long cone into the gun housing.
2. Screw in grip (2) into the gun housing and tighten.
3. Slot in protective guard (1).

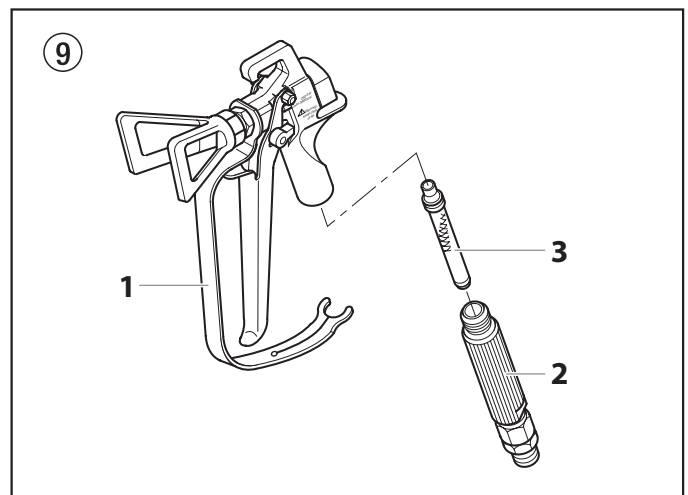

## 9. Remedy in case of faults

Type of malfunction	Possible cause	Measures for eliminating the malfunction
A. Unit does not start	<ol style="list-style-type: none"> <li>No voltage applied.</li> <li>Pressure setting too low.</li> <li>ON/OFF switch defective.</li> </ol>	<ol style="list-style-type: none"> <li>Check voltage supply.</li> <li>Turn up pressure control knob.</li> <li>Replace.</li> </ol>
B. Unit does not draw in material	<ol style="list-style-type: none"> <li>Relief valve is set to SPRAY (☞ spray).</li> <li>Filter projects over the fluid level and sucks air.</li> <li>Filter clogged.</li> <li>Suction hose/suction tube is loose, i.e. the unit is sucking in outside air.</li> </ol>	<ol style="list-style-type: none"> <li>Set relief valve to PRIME (☞ circulation).</li> <li>Refill the coating material.</li> <li>Clean or replace the filter.</li> <li>Clean connecting points. Replace O-rings if necessary. Secure suction hose with retaining clip.</li> </ol>
C. Unit draws in material, but the pressure does not build up	<ol style="list-style-type: none"> <li>Tip heavily worn.</li> <li>Tip too large.</li> <li>Pressure setting too low.</li> <li>Filter clogged.</li> <li>Coating material flows through the return hose when the relief valve is in the SPRAY (☞ spray) position.</li> <li>Packings sticky or worn.</li> <li>Valve balls worn.</li> <li>Valve seats worn.</li> </ol>	<ol style="list-style-type: none"> <li>Replace</li> <li>For selection of a smaller tip, see Tip table on Page 18.</li> <li>Turn pressure control knob clockwise to increase.</li> <li>Clean or replace the filter.</li> <li>Remove and clean or replace relief valve.</li> <li>Remove and clean or replace packings.</li> <li>Remove and replace valve balls.</li> <li>Remove and replace valve seats.</li> </ol>
D. Coating material exits at the top of the fluid section	<ol style="list-style-type: none"> <li>Upper packing is worn.</li> <li>Piston is worn.</li> </ol>	<ol style="list-style-type: none"> <li>Remove and replace packing.</li> <li>Remove and replace piston.</li> </ol>
E. Increased pulsation at the spray gun	<ol style="list-style-type: none"> <li>Incorrect high-pressure hose type.</li> <li>Tip worn or too large.</li> <li>Pressure too high.</li> </ol>	<ol style="list-style-type: none"> <li>Only use WAGNER original-high-pressure hoses in order to ensure functionality, safety and durability.</li> <li>Replace tip.</li> <li>Turn pressure control knob to a lower number.</li> </ol>
F. Poor spray pattern	<ol style="list-style-type: none"> <li>Tip is too large for the coating material which is to be sprayed.</li> <li>Pressure setting incorrect.</li> <li>Volume too low.</li> <li>Coating material viscosity too high.</li> </ol>	<ol style="list-style-type: none"> <li>Replace tip, see Tip table on Page 18.</li> <li>Turn pressure control knob until a satisfactory spraying pattern is achieved.</li> <li>Clean or replace all filters.</li> <li>Thin out according to the manufacturer's instructions.</li> </ol>
G. Unit loses power	<ol style="list-style-type: none"> <li>Pressure setting too low.</li> </ol>	<ol style="list-style-type: none"> <li>Turn pressure control knob clockwise to increase.</li> </ol>

## 10. Servicing

### 10.1 General servicing

Servicing of the unit should be carried out once annually by the WAGNER service.

1. Check high-pressure hoses, device connecting line and plug for damage.
2. Check the inlet valve, outlet valve and filter for wear.

### 10.2 High-pressure hose

Inspect the high-pressure hose visually for any notches or bulges, in particular at the transition in the fittings. It must be possible to turn the union nuts freely.



**The risk of damage rises with the age of the high-pressure hose. Wagner recommends replacing high-pressure hoses after 6 years.**

## 11. Repairs at the unit



**Switch the unit OFF. Before all repair work: Unplug the power plug from the outlet.**

### 11.1 Relief valve

1. Use a drift punch of 2 mm to remove the grooved pin (Fig. 10, Item 1) from the relief valve handle (2).
2. Remove the relief valve handle (2) and cam base (3).
3. Using a wrench, remove the valve housing (4) from the pump manifold (6).
4. Ensure that the seal (5) is seated correctly, then screw the new valve housing (4) completely into the pump manifold (6). Tighten securely with a wrench.
5. Align the cam base (3) with the hole in the pump manifold (6). Lubricate the cam base with grease and slide on the cam base.
6. Bring the hole in the valve shaft (7) and in the relief valve handle (2) into alignment.
7. Insert the grooved pin (1) to secure the relief valve handle in position.

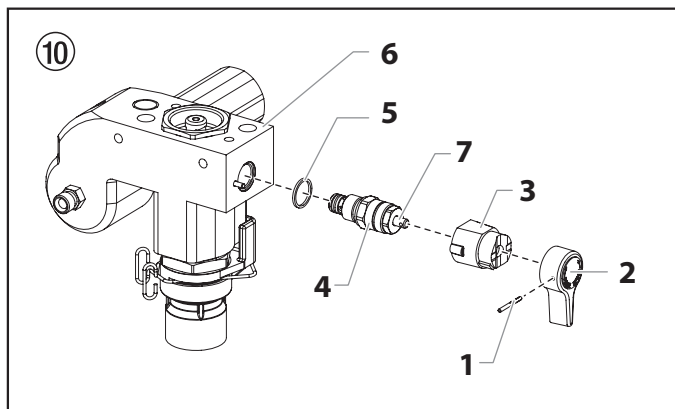

### 11.2 Inlet and outlet valve

1. Remove the four screws in the front cover and then remove the front cover.
2. Switch the unit ON and then OFF so that the piston rod is positioned in the lower stroke position.



**Danger of crushing - do not reach with the fingers or tool between the moving parts.**

3. Unplug the power plug from the outlet.
4. Remove the retaining clip from the connecting bend at the suction hose and pull off the suction hose.
5. Screw off the return hose.
6. Swivel the unit 90° to the rear in order to work more easily on the material feed pump.
7. Remove the pusher stem clip and slide the pusher stem housing (7) from the inlet valve housing (1).
8. Unscrew the inlet valve housing (Fig. 11, Item 1) from the pump manifold.
9. Remove the lower seal (2), lower ball guide (3), inlet valve ball (4), inlet valve seat (5) and O-ring (6).
10. Clean all the parts with the corresponding cleaning agent. Check the inlet valve housing (1), inlet valve seat (5) and inlet valve ball (4) for wear and replace the parts if necessary. If the worn inlet valve seat (5) is unused on one side, install it the other way round.

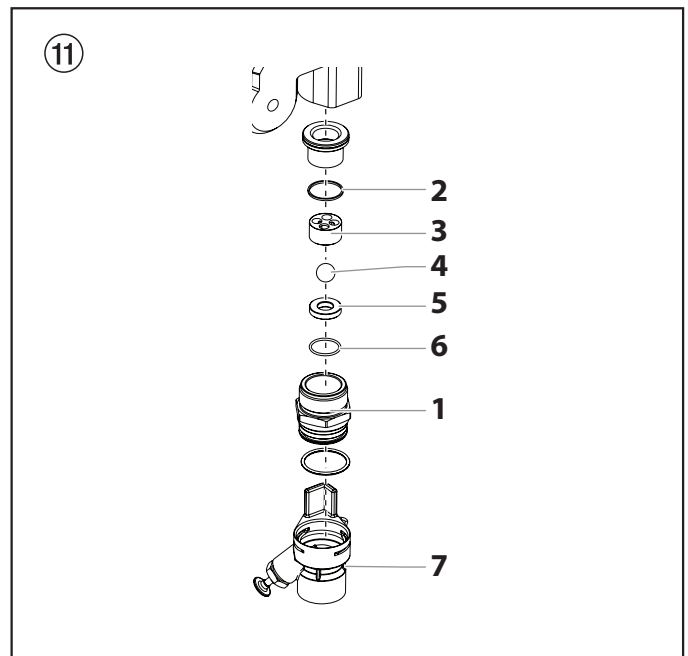

11. Unscrew outlet valve housing (Fig. 12, Item 8) from the piston (9) with adjusting wrench.
12. Remove the upper ball cage (11), crush washer (10), outlet valve ball (12), and outlet valve seat (13).
13. Clean all the parts with the corresponding cleaning agent. Check outlet valve housing (8), outlet valve seat (13), outlet valve ball (12), crush washer (10), and upper ball cage (11) for wear and replace parts if necessary. If the worn outlet valve seat (13) is unused on one side, install it the other way round.
14. Carry out installation in the reverse order. Lubricate O-ring (Fig. 11, Item 6) with machine grease and ensure proper seating in the inlet valve housing (Fig. 11, Item 1).

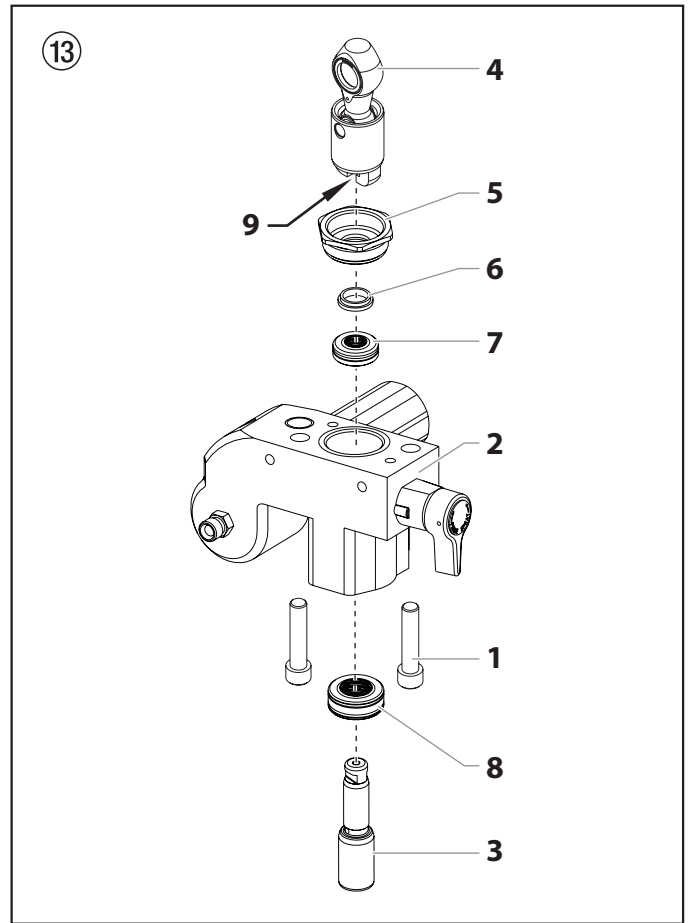
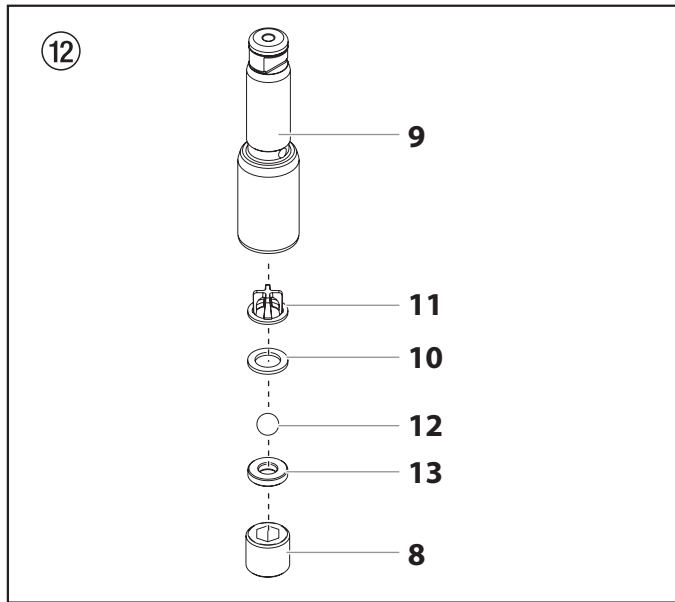

### 11.3 Packings

1. Remove inlet valve housing in accordance with the steps in Chapter 11.2, Page 14.
2. It is not necessary to remove the outlet valve.
3. Unscrew both cylinder head screws (Fig. 13, Item 1) from the pump manifold (2) with a 3/8 inch hexagon socket head wrench.
4. Slide the pump manifold (2) and piston (3) forward until the piston is out of the T-slot (9) on the slider assembly (4).
5. Push piston (3) downward out of the pump manifold (2).
6. Unscrew retainer nut (5) from the pump manifold (2) and remove piston guide (6).
7. Remove upper packing (7) and lower packing (8) from the pump manifold (2).

8. Clean pump manifold (2).
9. Lubricate upper packing (7) and lower packing (8) with machine grease.
10. Insert upper packing (Fig. 14) with O-ring (1) and protruding lip (2) downward.

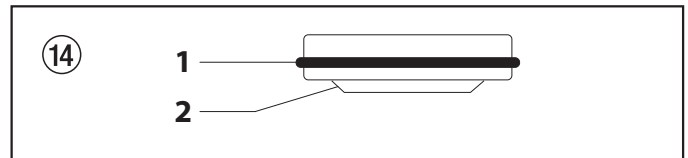

11. Insert lower packing (Fig. 15) with the beveled edge (1) facing upward.

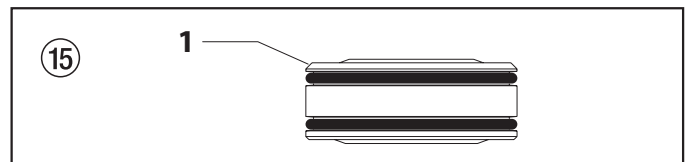

12. Insert piston guide (Fig. 13, Item 6) into the retainer nut (5). Screw retainer nut (5) into the pump manifold (2) and tighten by hand.
13. Push installation tool (included with the replacement packings) for the piston (3) from above onto the piston.
14. Lubricate installation tool and piston (3) with machine grease.
15. Guide piston (3) through the lower packings (8) into the pump manifold (2) from below. Using a rubber mallet, lightly tap the piston (3) from below until it can be seen above the pump manifold.
16. Remove installation tool from piston (3).
17. Carefully tighten retainer nut (5) with adjusting wrench

18. Slide the top of the piston (3) into the T-slot (9) on the slider assembly (4).
19. Position the pump manifold (2) underneath the gear unit housing and push up until it rests against the gear unit housing.
20. Attach pump manifold (2) to the gear unit housing.
21. Screw pump manifold (2) tightly to gear unit housing.
22. Lubricate O-ring (Fig. 11, Item 6) between pump manifold (2) and inlet valve housing with machine grease. Screw inlet valve housing to the pump manifold.
23. Insert the elbow on the siphon assembly into the bottom of the pusher stem housing. Push the retaining clip up into the groove inside the foot valve housing to secure the siphon assembly in position. Place the return tube over the return tube fitting and secure with the clip.
24. Install front cover.

### 11.4 ProSpray 3.23 connection diagram

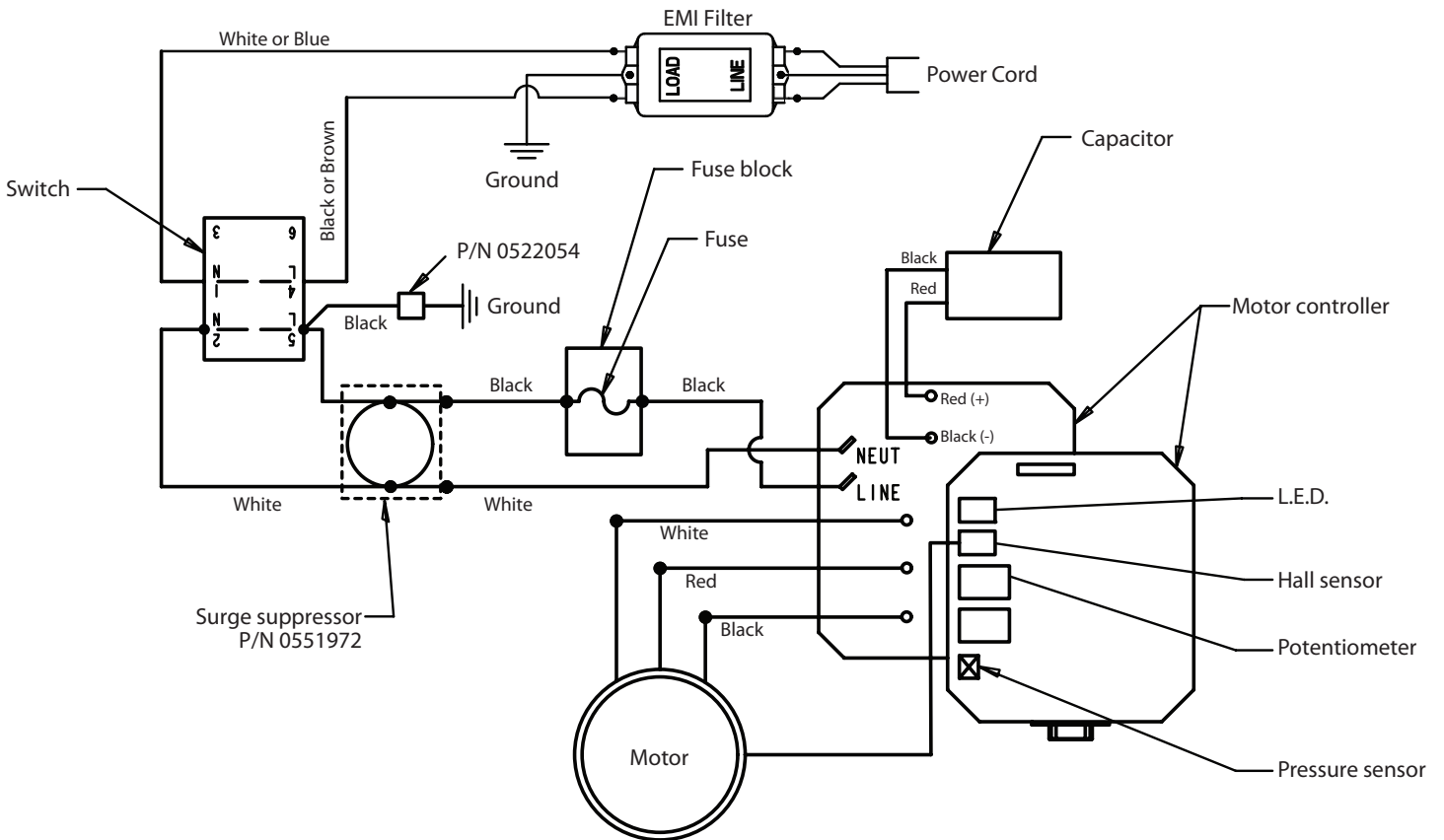





## 12.4 Airless tip table

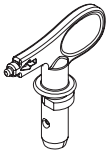

**Wagner TradeTip 3 tip**  
up to 270 bar  
(27 MPa)

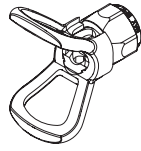

without tip  
F thread (11/16 - 16 UN)  
for Wagner spray guns  
**Order no. 0289391**

without tip  
G thread (7/8 - 14 UN)  
for Graco/Titan spray guns  
**Order no. 0289390**



All of the tips in the table below are supplied together with the appropriate gun filter.

Application	Tip marking	Spray angle	Bore inch / mm	Spraying width mm 1)	Gun filter	Order no.
<b>Water-thinnable and solvent-based paints and varnishes, oils, separating agents</b>	107	10°	0.007 / 0.18	100	red	0553107
	207	20°	0.007 / 0.18	120	red	0553207
	307	30°	0.007 / 0.18	150	red	0553307
	407	40°	0.007 / 0.18	190	red	0553407
	109	10°	0.009 / 0.23	100	red	0553109
	209	20°	0.009 / 0.23	120	red	0553209
	309	30°	0.009 / 0.23	150	red	0553309
	409	40°	0.009 / 0.23	190	red	0553409
	509	50°	0.009 / 0.23	225	red	0553509
	609	60°	0.009 / 0.23	270	red	0553609
<b>Synthetic-resin paints PVC paints</b>	111	10°	0.011 / 0.28	100	red	0553111
	211	20°	0.011 / 0.28	120	red	0553211
	311	30°	0.011 / 0.28	150	red	0553311
	411	40°	0.011 / 0.28	190	red	0553411
	511	50°	0.011 / 0.28	225	red	0553511
	611	60°	0.011 / 0.28	270	red	0553611
<b>Paints, primers Fillers</b>	113	10°	0.013 / 0.33	100	red	0553113
	213	20°	0.013 / 0.33	120	red	0553213
	313	30°	0.013 / 0.33	150	red	0553313
	413	40°	0.013 / 0.33	190	red	0553413
	513	50°	0.013 / 0.33	225	red	0553513
	613	60°	0.013 / 0.33	270	red	0553613
	813	80°	0.013 / 0.33	330	red	0553813
<b>Fillers Rust protection paints</b>	115	10°	0.015 / 0.38	100	yellow	0553115
	215	20°	0.015 / 0.38	120	yellow	0553215
	315	30°	0.015 / 0.38	150	yellow	0553315
	415	40°	0.015 / 0.38	190	yellow	0553415
	515	50°	0.015 / 0.38	225	yellow	0553515
	615	60°	0.015 / 0.38	270	yellow	0553615
	715	70°	0.015 / 0.38	300	yellow	0553715
	815	80°	0.015 / 0.38	330	yellow	0553815
<b>Rust protection paints Latex paints Dispersions</b>	117	10°	0.017 / 0.43	100	yellow	0553117
	217	20°	0.017 / 0.43	120	yellow	0553217
	317	30°	0.017 / 0.43	150	yellow	0553317
	417	40°	0.017 / 0.43	190	yellow	0553417
	517	50°	0.017 / 0.43	225	yellow	0553517
	617	60°	0.017 / 0.43	270	yellow	0553617
	717	70°	0.017 / 0.43	300	yellow	0553717
	817	80°	0.017 / 0.43	330	yellow	0553817
<b>Rust protection paints Latex paints Dispersions</b>	219	20°	0.019 / 0.48	120	white	0553219
	319	30°	0.019 / 0.48	150	white	0553319
	419	40°	0.019 / 0.48	190	white	0553419
	519	50°	0.019 / 0.48	225	white	0553519
	619	60°	0.019 / 0.48	270	white	0553619
	719	70°	0.019 / 0.48	300	white	0553719
	819	80°	0.019 / 0.48	330	white	0553819
	919	90°	0.019 / 0.48	385	white	0553919
	<b>Flame retardant</b>	221	20°	0.021 / 0.53	120	white
321		30°	0.021 / 0.53	150	white	0553321
421		40°	0.021 / 0.53	190	white	0553421
521		50°	0.021 / 0.53	225	white	0553521
621		60°	0.021 / 0.53	270	white	0553621
721		70°	0.021 / 0.53	300	white	0553721
821		80°	0.021 / 0.53	330	white	0553821

1) Spray width at about 30 cm to the object and 100 bar (10 MPa) pressure with synthetic-resin paint 20 DIN seconds.

Application	Tip marking	Spray angle	Bore inch / mm	Spraying width mm 1)	Gun filter	Order no.
<b>Roof coatings</b>	223	20°	0.023 / 0.58	120	white	0553223
	323	30°	0.023 / 0.58	150	white	0553323
	423	40°	0.023 / 0.58	190	white	0553423
	523	50°	0.023 / 0.58	225	white	0553523
	623	60°	0.023 / 0.58	270	white	0553623
	723	70°	0.023 / 0.58	300	white	0553723
	823	80°	0.023 / 0.58	330	white	0553823
<b>Thick-film materials, Corrosion protection Spray filler</b>	225	20°	0.025 / 0.64	120	white	0553225
	325	30°	0.025 / 0.64	150	white	0553325
	425	40°	0.025 / 0.64	190	white	0553425
	525	50°	0.025 / 0.64	225	white	0553525
	625	60°	0.025 / 0.64	270	white	0553625
	725	70°	0.025 / 0.64	300	white	0553725
	825	80°	0.025 / 0.64	330	white	0553825
	227	20°	0.027 / 0.69	120	white	0553227
	327	30°	0.027 / 0.69	150	white	0553327
	427	40°	0.027 / 0.69	190	white	0553427
	527	50°	0.027 / 0.69	225	white	0553527
	627	60°	0.027 / 0.69	270	white	0553627
	827	80°	0.027 / 0.69	330	white	0553827
	229	20°	0.029 / 0.75	120	white	0553229
	329	30°	0.029 / 0.75	150	white	0553329
	429	40°	0.029 / 0.75	190	white	0553429
	529	50°	0.029 / 0.75	225	white	0553529
	629	60°	0.029 / 0.75	270	white	0553629
	231	20°	0.031 / 0.79	120	white	0553231
	331	30°	0.031 / 0.79	150	white	0553331
	431	40°	0.031 / 0.79	190	white	0553431
	531	50°	0.031 / 0.79	225	white	0553531
	631	60°	0.031 / 0.79	270	white	0553631
	731	70°	0.031 / 0.79	300	white	0553731
	831	80°	0.031 / 0.79	330	white	0553831
	233	20°	0.033 / 0.83	120	white	0553233
	333	30°	0.033 / 0.83	150	white	0553333
	433	40°	0.033 / 0.83	190	white	0553433
	533	50°	0.033 / 0.83	225	white	0553533
	633	60°	0.033 / 0.83	270	white	0553633
	235	20°	0.035 / 0.90	120	white	0553235
	335	30°	0.035 / 0.90	150	white	0553335
	435	40°	0.035 / 0.90	190	white	0553435
	535	50°	0.035 / 0.90	225	white	0553535
	635	60°	0.035 / 0.90	270	white	0553635
	735	70°	0.035 / 0.90	300	white	0553735
	439	40°	0.039 / 0.99	190	white	0553439
539	50°	0.039 / 0.99	225	white	0553539	
639	60°	0.039 / 0.99	270	white	0553639	
<b>Heavy duty applications</b>	243	20°	0.043 / 1.10	120	green	0553243
	443	40°	0.043 / 1.10	190	green	0553443
	543	50°	0.043 / 1.10	225	green	0553543
	643	60°	0.043 / 1.10	270	green	0553643
	445	40°	0.045 / 1.14	190	green	0553445
	545	50°	0.045 / 1.14	225	green	0553545
	645	60°	0.045 / 1.14	270	green	0553645
	451	40°	0.051 / 1.30	190	green	0553451
	551	50°	0.051 / 1.30	225	green	0553551
	651	60°	0.051 / 1.30	270	green	0553651
	252	20°	0.052 / 1.32	120	green	0553252
	455	40°	0.055 / 1.40	190	green	0553455
	555	50°	0.055 / 1.40	225	green	0553555
	655	60°	0.055 / 1.40	270	green	0553655
	261	20°	0.061 / 1.55	120	green	0553261
	461	40°	0.061 / 1.55	190	green	0553461
	561	50°	0.061 / 1.55	225	green	0553561
	661	60°	0.061 / 1.55	270	green	0553661
	263	20°	0.063 / 1.60	120	green	0553263
	463	40°	0.063 / 1.60	190	green	0553463
	565	50°	0.065 / 1.65	225	green	0553565
	665	60°	0.065 / 1.65	270	green	0553665
	267	20°	0.067 / 1.70	120	green	0553267
467	40°	0.067 / 1.70	190	green	0553467	

1)Spray width at about 30 cm to the object and 100 bar (10 MPa) pressure with synthetic-resin paint 20 DIN seconds.

## 12.5 Pump-Runner

(Order No. 2306987)

Universal accessories for cleaning, clean transportation and preservation of the pump unit.

**Features:**

- Simpler cleaning – the cleaning liquid circulates constantly through the pump making thorough cleaning of the interior
- No cleaning necessary during work stoppage or change of location because the paint in the pump cannot dry out or leak
- Better protection
- Simple assembly

**Suitable for the following models:**

Diaphragm Pumps		Double-stroke piston pumps	
SF 21	Finish 270/370	PS 24	PS 3.25
SF 23	Nespray Deco	PS 26	PS 3.29
SF 27	Nespray 31	PS 30	PS 3.31
SF 31		PS 34	PS 3.34
SF 7000			



**Order this at the same time: EasyClean, cleaning and preservation agent (118ml) Order no. 0508 620.**

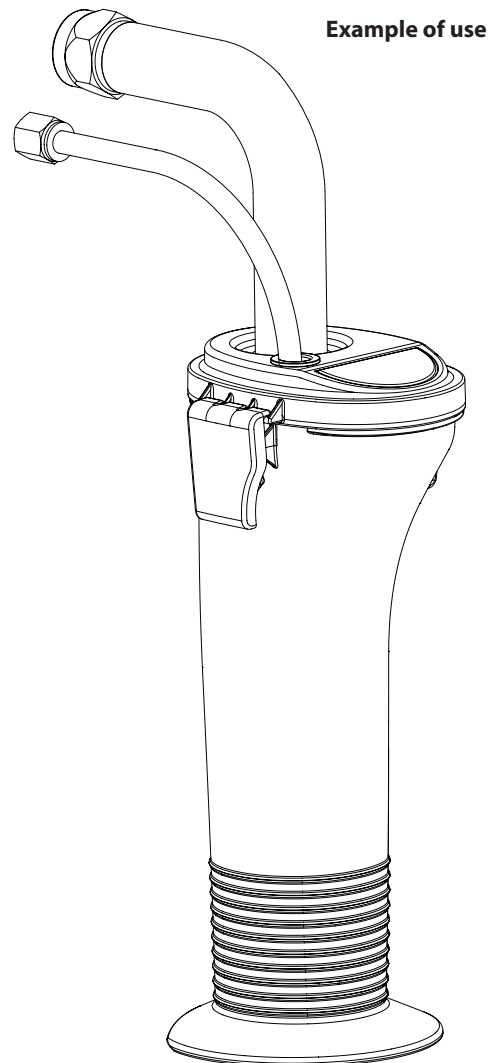
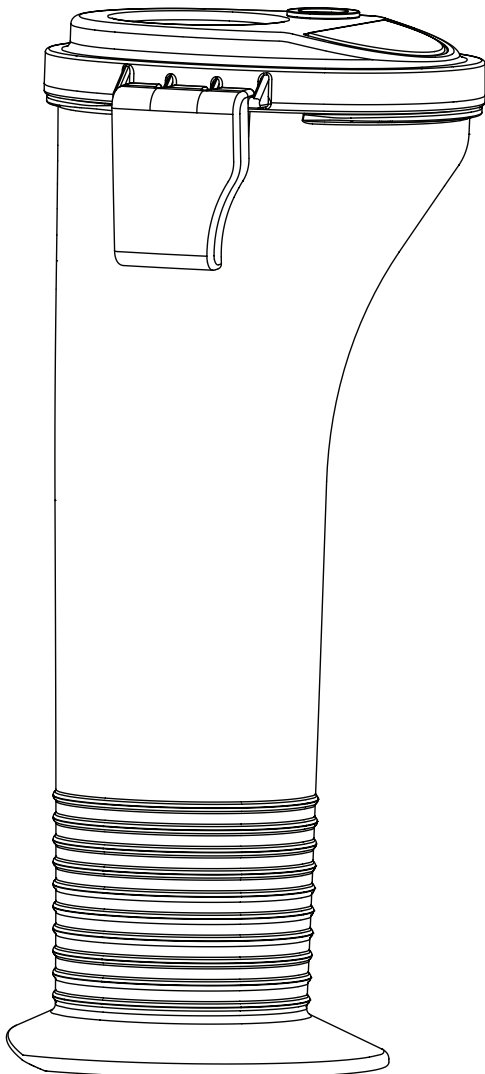

- A** J. Wagner Ges.m.b.H.  
Ottogasse 2/20  
2333 Leopoldsdorf  
Österreich  
Tel. +43/ 2235 / 44 158  
Telefax +43/ 2235 / 44 163  
office@wagner-group.at
- B** WSB Finishing Equipment  
Veilinglaan 56-58  
1861 Wolvertem  
Belgium  
Tel. +32/2/269 46 75  
Telefax +32/2/269 78 45  
info@wagner-wsb.nl
- CH** Wagner International AG  
Industriestrasse 22  
9450 Altstätten  
Schweiz  
Tel. +41/71 / 7 57 22 11  
Telefax +41/71 / 7 57 22 22  
wagner@wagner-group.ch
- D** J. Wagner GmbH  
Otto-Lilienthal-Straße 18  
D-88677 Markdorf  
Postfach 11 20  
Deutschland  
Tel. +49 / 75 44 / 505-1664  
Telefax +49 / 75 44 / 505-1155  
wagner@wagner-group.com  
www.wagnergroup.com
- DK** Wagner Spraytech  
Scandinavia A/S  
Helgeshøj Allé 28  
2630 Taastrup  
Denmark  
Tel. +45/43/ 27 18 18  
Telefax +45/43/ 43 05 28  
wagner@wagner-group.dk
- E** Wagner Spraytech Iberica S.A.  
P.O. Box 132, Crta. N-340  
08750 Molins de Rey  
Barcelona / Espania  
Tel. +34/93/6800028  
Telefax +34/93/66800555  
info@wagnerspain.com
- F** Wagner France  
12 Avenue des Tropiques  
Z.A. de Courtaboeuf,  
91978 Les Ulis Cedex  
France  
Tel. 0 825 011 111  
Telefax +33 (0) 69 81 72 57  
division.batiment@wagner-france.fr
- CZ** Wagner, spol. s r.o.  
Nedasovská str. 345  
155 21 Praha 5 -Zlicín  
Czechia  
Tel. +42/ 2 / 579 50 412  
Telefax +42/ 2 / 579 51 052  
info@wagner.cz
- GB** Wagner Spraytech (UK) Limited  
The Coach House  
2 Main Road  
Middleton Cheney OX17 2ND  
Great Britain  
UK-Helpline 0844 335 0517  
5 p per minute (landline)
- I** Wagner Colora Srl  
Via Italia 34  
20060 Gessate - MI  
Italia  
Tel. +39 02.9592920.1  
Telefax +39 02.95780187  
info@wagnercolora.com
- NL** WSB Finishing Equipment BV  
De Heldinnenlaan 200  
3543 MB Utrecht  
Netherlands  
Tel. +31/ 30/241 41 55  
Telefax +31/ 30/241 17 87  
info@wagner-wsb.nl
- S** Wagner Spraytech  
Scandinavia A/S  
Helgeshøj Allé 28  
2630 Taastrup  
Denmark  
Tel. +45/43/ 21 18 18  
Telefax +45/43/ 43 05 28  
wagner@wagner-group.dk

**www.wagner-group.com**

# Accessories illustration

## ProSpray 3.23

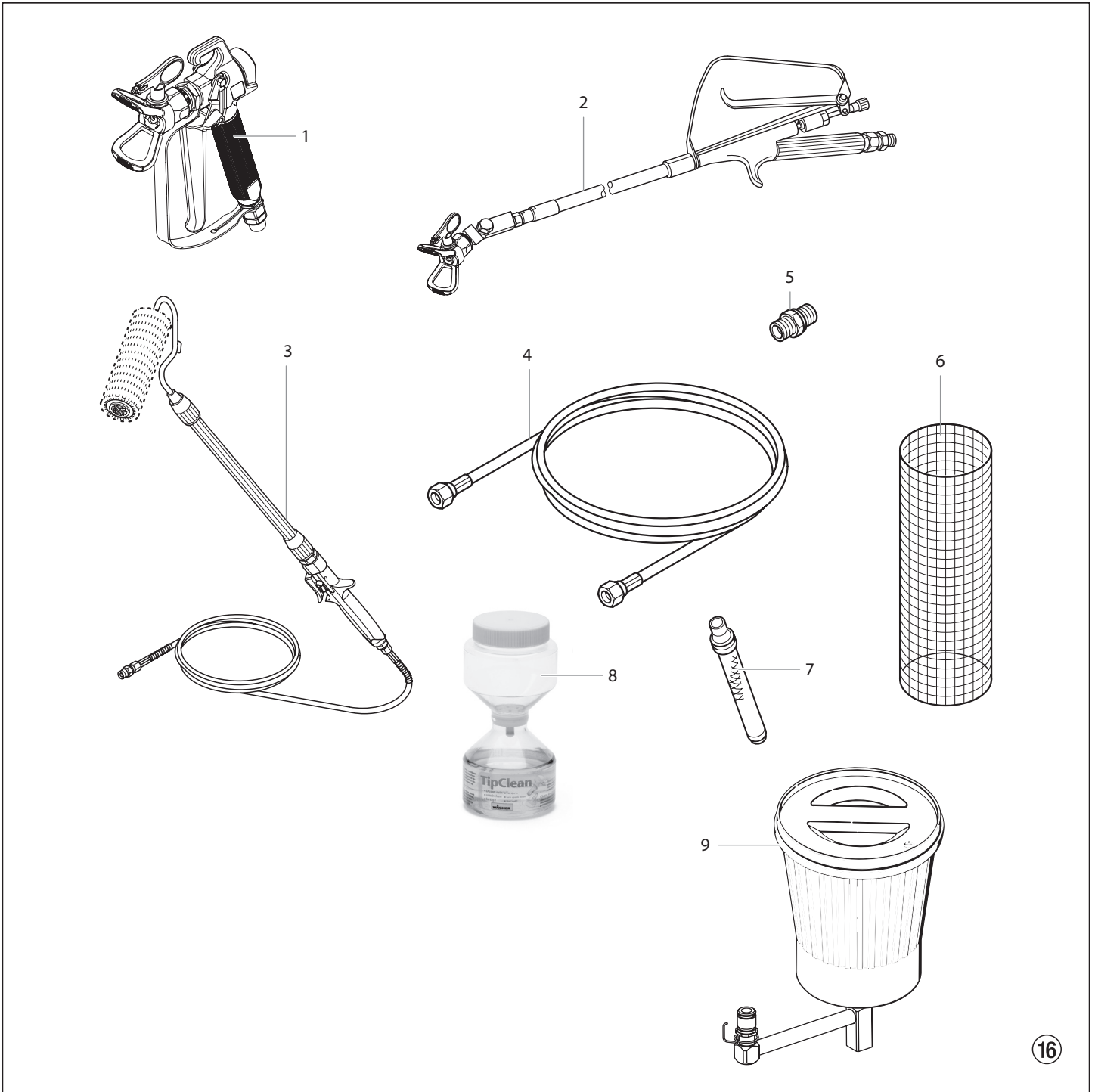

Item	Part No.	Description
1	0296 388	Spray gun AG 08, F-thread
	0296 386	Spray gun AG 08, G-thread
	0502 166	Spray gun AG 14, F-thread
	0502 119	Spray gun AG 14, G-thread
2	0296 441	Pole gun 120 cm, G-thread 7/8"
	0296 443	Pole gun 120 cm, F-thread 11/16"
	0296 442	Pole gun 200 cm, G-thread 7/8"
	0296 444	Pole gun 200 cm, F-thread 11/16"
3	0345 010	In-line roller IR-100
4	9984 573	High-pressure hose DN 4 mm, 7.5 m with stainless steel nipple, 1/4"
	9984 574	High-pressure hose DN 6 mm, 15 m for dispersion, 1/4"
	9984 575	High-pressure hose DN 6 mm, 30 m for dispersion, 1/4"
5	0034 038	Double socket for coupling high-pressure hoses (1/4" x 1/4")
6	0034 950	Metex-Reuse Reuse for pre-filtering of coating material in vessel. Place suction pipe in the reuse.
	0034 952	Sieve package (5 pcs) for paint
	0034 951	Sieve package (5 pcs) for dispersion
7	0034 383	Gun filter, red, 1 piece; 180 mesh extra fine
	0097 022	Gun filter, red, 10 pieces; 180 mesh extra fine
	0043 235	Gun filter, yellow, 1 piece; 100 mesh fine
	0097 023	Gun filter, yellow, 10 pieces; 100 mesh fine
	0034 377	Gun filter, white, 1 piece; 50 mesh medium
	0097 024	Gun filter, white, 10 pieces; 50 mesh medium
	0089 323	Gun filter, green, 1 piece; 30 mesh coarse
	0097 025	Gun filter, green, 10 pieces; 30 mesh coarse
8	0097 108	TipClean Cleaning Set for easy cleaning and conservation of nozzles
	0508 619	EasyGlide, special oil (118ml)
	0508 620	EasyClean, cleaning and conservation agent (118 ml)
9	0551 969	Hopper kit

# Spare parts list

## ProSpray 3.23

### Main Assembly

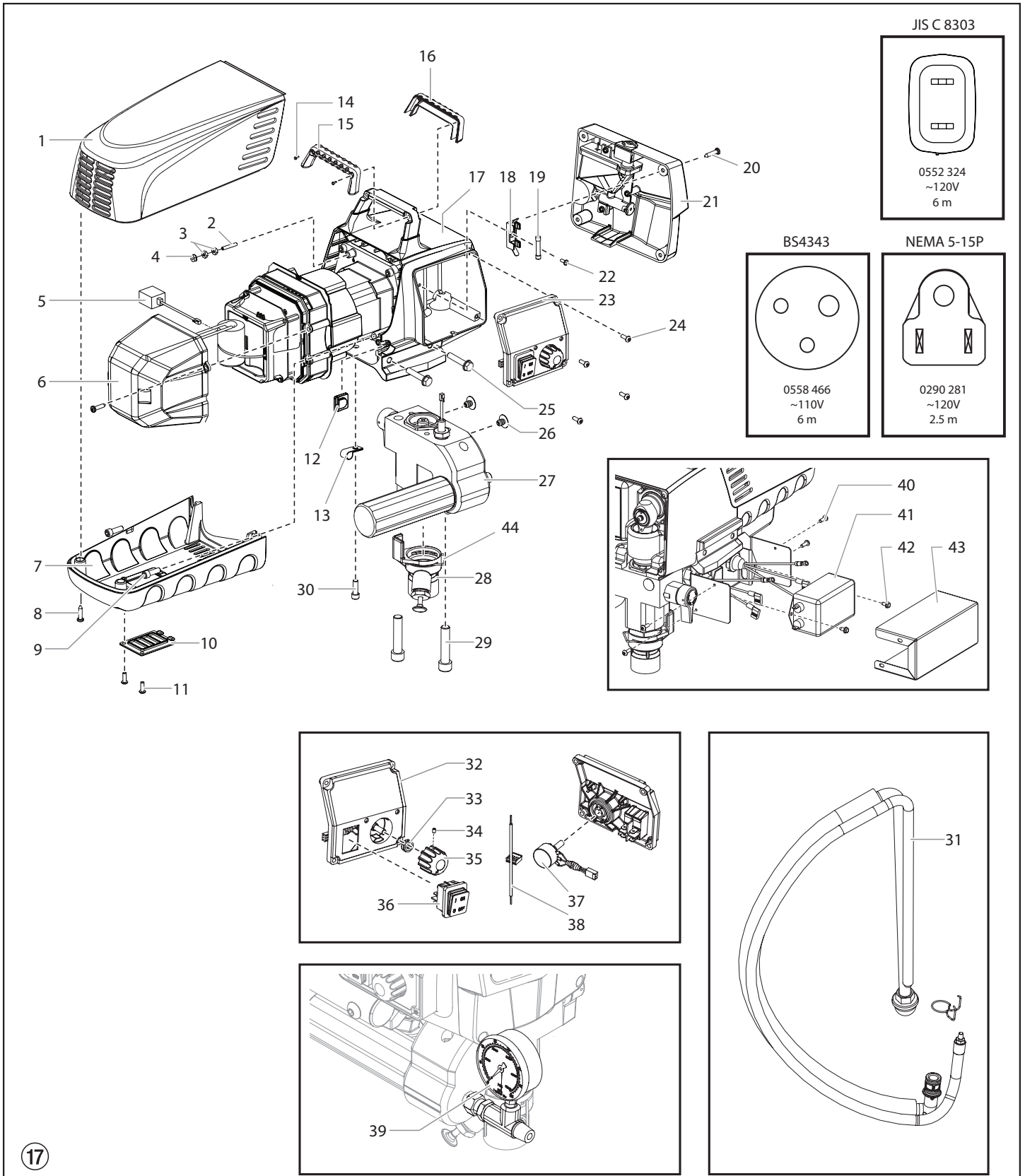



Item	Part No.	Description
1	0290 230	Motor shroud
2	9805 403	Set screw
3	9810 103	Nut
4	0524 353	Nut
5	0551 757	Transducer jumper
6	0290 225	Electronic cover
7	0290 229	Belly pan
8	9802 266	Screw (2)
9	0508 559	Screw (2)
10	0290 228	Door
11	0509 218	Screw (2)
12	0558 460	Plug*
13	-----	Strap*
14	9805 317	Screw (2)
15	0290 212	Handle cover, back
16	0290 213	Handle cover, front
17	-----	Drive assembly
18	0522 210	Mounting plate
19	0551 627	Fuse, 15A
20	0509 218	Screw (4)
21	0290 278	Face plate / oiler assembly
22	9804 916	Screw
23	0558 305A	Control panel assembly, complete (includes items 32-38)

Item	Part No.	Description
24	0509 218	Screw (4)
25	9805 348	Screw (4)
26	0509 636	Plug (2)
27	0558 298A	Fluid section assembly
28	0290 205	Pusher assembly (includes item 44)
29	0508 553	Screw (2)
30	0508 559	Screw
31	0558 672	Siphon assembly
32	0290 227	Control panel cover with label
33	0507 749	Nut with seal
34	0290 202	Set screw
35	0290 218	Knob
36	9850 936	Switch
37	0508 579	Potentiometer
38	0522 007	LED assembly
39	0508 239	Manometer
40	0509 218	Screw (4)*
41	0522 424	EMI filter, 20A*
42	9800 340	Ground screw (2)*
43	0558 452	Bracket cover (2)*
44	0558 742	Clip
	0551 792	Surge protector (not shown, see schematic)
	0522 054	Arrestor (not shown, see schematic)

\* UK only

# Spare parts list

## ProSpray 3.23

### Fluid section

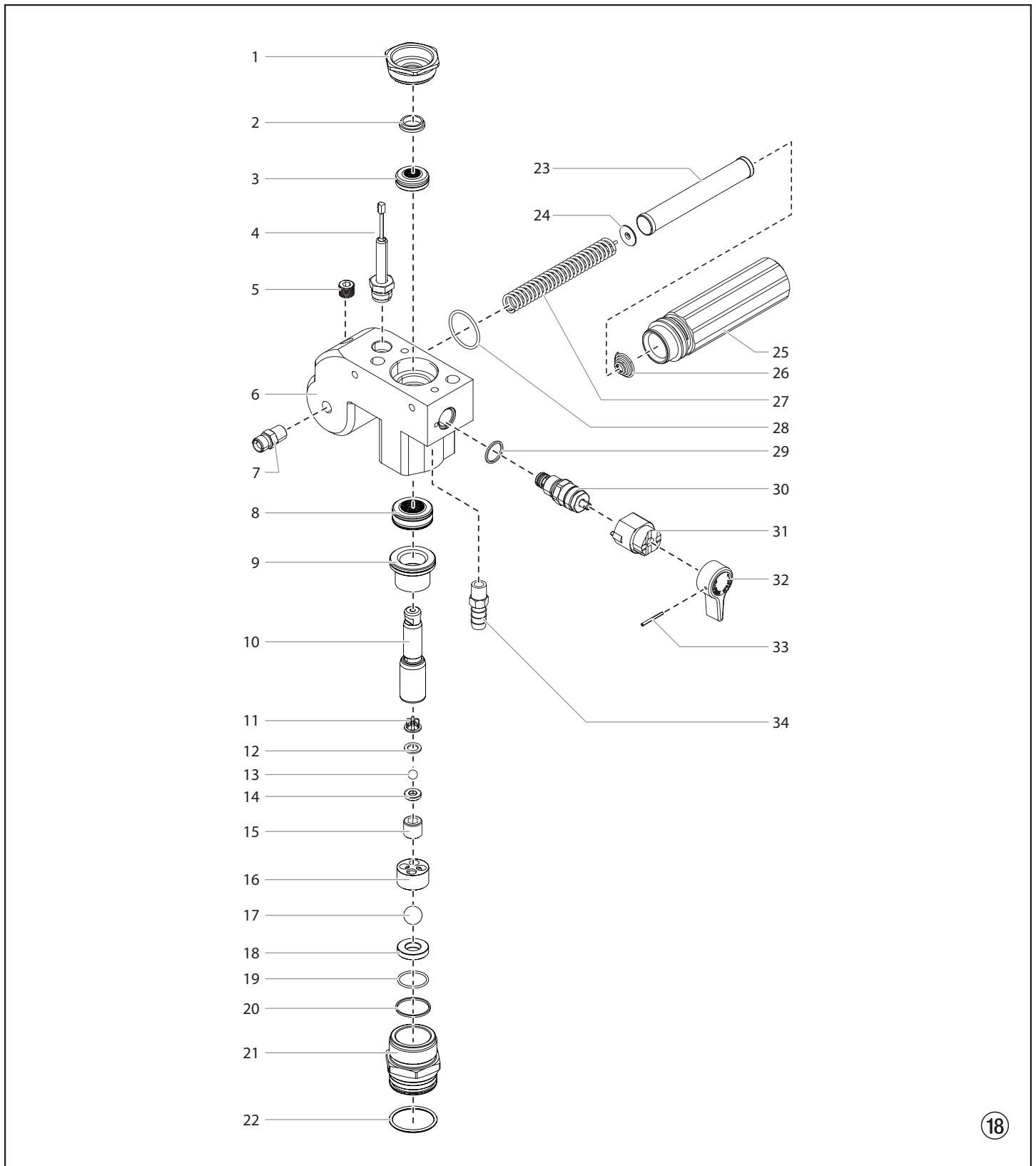

<b>Item</b>	<b>Part No.</b>	<b>Description</b>
1	0509 594	Retainer
2	0509 584	Piston guide
3	-----	Upper packing
4	0551 756	Transducer assembly
5	0507 517	Pipe plug
6	0290 209	Pump manifold
7	0509 873	Fitting
8	-----	Lower packing
9	0552 489	Bushing
10	0290 277	Piston rod
11	0551 262	Upper cage
12	0551 263	Crush washer
13	50164	Outlet valve ball
14	0551 620	Outlet valve seat
15	13481	Outlet valve retainer
16	0509 591	Lower ball guide
17	0509 583	Inlet valve ball
18	0551 534	Inlet valve seat
19	0509 582	O-ring, PTFE
20	0509 581	Inlet valve seal
21	0290 216	Inlet valve housing
22	9871 160	O-ring
23	0508 748	Filter
24	0508 603	Bearing ring
25	0508 601	Filter housing
26	0508 602	Conical spring
27	0508 749	Bearing spring
28	0508 604	O-ring
29	0507 745	Gasket
30	0558 727	Bypass valve assembly (includes item 29)
31	0507 931	Cam base
32	0508 744	Relief valve knob
33	5006 543	Groove pin
34	193-200	Return tube fitting
	0509 151	Piston assembly (includes items 10-15)
	0290 201	Repacking kit - 1 (includes items 2-3, 8, 11-13, 17 and 19-20).
	0558 728	Repacking kit - 2 (includes items 2-3 and 8).
	0507 254	Relief valve kit (includes items 29-33).

# Spare parts list

## ProSpray 3.23

### Drive Assembly

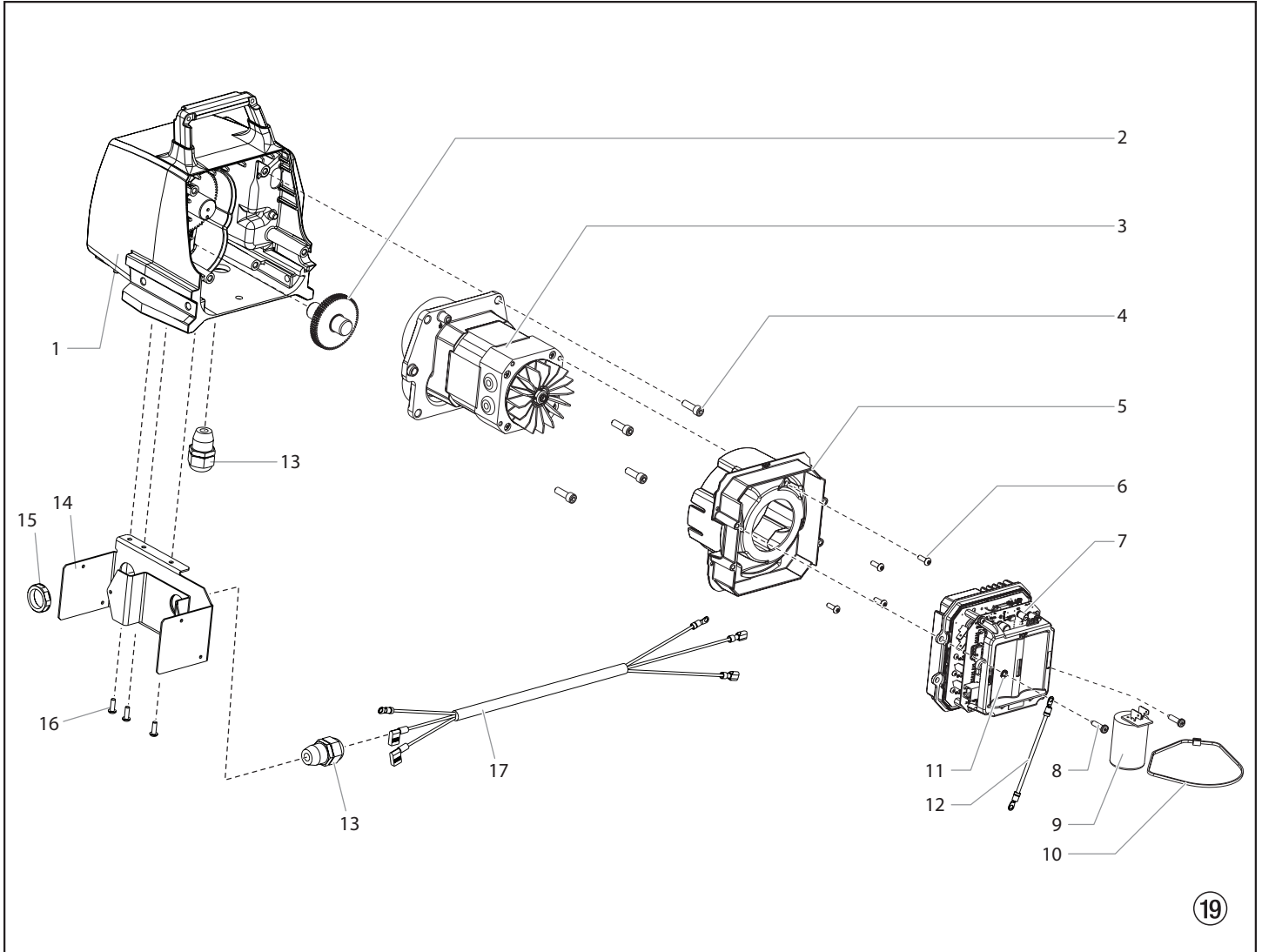

<b>Item</b>	<b>Part No.</b>	<b>Description</b>
1	0524 637A	Housing assembly
2	0509 121	2nd stage gear
3	0290 282	Motor assembly
4	0508 559	Screw (4)
5	0290 226	Baffle assembly
6	0509 218	Screw (2)
7	0558 539	Electronic control assembly
8	9802 266	Screw
9	0522 023	Capacitor assembly
10	0551 543	Tie wrap
11	9822 106	Washer
12	0522 040	Wire assembly
13	0551 714	Cord grip (2)
14	0558 449	Bracket*
15	0551 980	Lock nut*
16	0509 218	Screw (3)*
17	0558 476	Power cord jumper*

\* UK only

## Spare parts list

### ProSpray 3.23

#### Stand

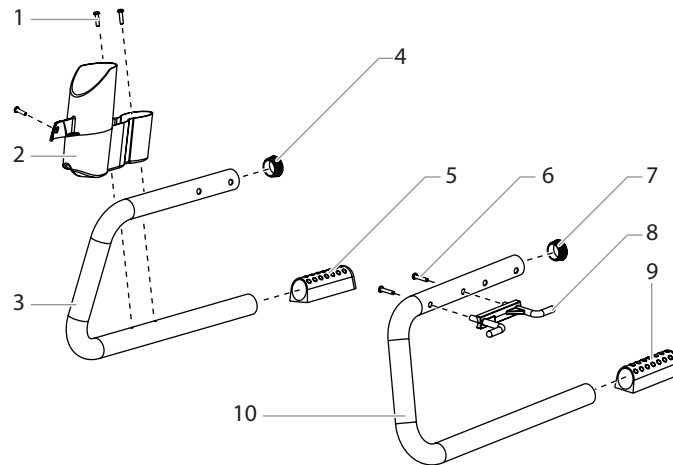

20

Item	Part No.	Description
1	9805 367	Screw (3)
2	0290 215	Drip cup
3	0290 211	Leg, right
4	0294 635	Plug
5	0290 214	Foot
6	0508 660	Screw (2)
7	0294 635	Plug
8	0290 219	Cord holder
9	0290 214	Foot
10	0290 210	Leg, left
	0290 203	Left leg assembly (includes items 6-10)
	0290 204	Right leg assembly (includes items 1-5)

## Spare parts list

### ProSpray 3.23

#### Suction system

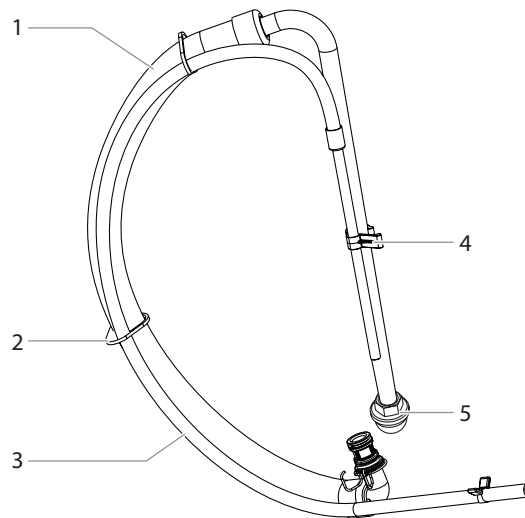

21

Item	Part No.	Description
1	0551 706	Siphon hose
2	9850 638	Tie wrap (2)
3	0558 659A	Return tube
4	0279 459	Clip
5	0508 738	Filter
	0558 672	Siphon tube assembly (includes items 1-5)

## Important notes on product liability

As a result of an EC regulation being effective as from January 1, 1990, the manufacturer shall only be liable for his product if all parts come from him or are released by him, and if the devices are properly mounted and operated.

If the user applies outside accessories and spare parts, the manufacturer's liability can fully or partially be inapplicable; in extreme cases usage of the entire device can be prohibited by the competent authorities (employer's liability insurance association and factory inspectorate division).

Only the usage of original WAGNER accessories and spare parts guarantees that all safety regulations are observed.

## 3+2 years guarantee for professional finishing

Wagner professional guarantee  
(Status 01.02.2009)

### 1. Scope of guarantee

All Wagner professional colour application devices (hereafter referred to as products) are carefully inspected, tested and are subject to strict checks under Wagner quality assurance. Wagner exclusively issues extended guarantees to commercial or professional users (hereafter referred to as "customer") who have purchased the product in an authorised specialist shop, and which relate to the products listed for that customer on the Internet under [www.wagner-group.com/profi-guarantee](http://www.wagner-group.com/profi-guarantee).

The buyer's claim for liability for defects from the purchase agreement with the seller as well as statutory rights are not impaired by this guarantee.

We provide a guarantee in that we decide whether to replace or repair the product or individual parts, or take the device back and reimburse the purchase price. The costs for materials and working hours are our responsibility. Replaced products or parts become our property.

### 2. Guarantee period and registration

The guarantee period amounts to 36 months. For industrial use or equal wear, such as shift operations in particular, or in the event of rentals it amounts to 12 months.

Systems driven by petrol or air are also guaranteed for a 12 month period.

The guarantee period begins with the day of delivery by the authorised specialist shop. The date on the original purchase document is authoritative.

For all products bought in authorised specialist shops from 01.02.2009 the guarantee period is extended to 24 months providing the buyer of these devices registers in accordance with the following conditions within 4 weeks of the day of delivery by the authorised specialist shop.

Registration can be completed on the Internet under [www.wagner-group.com/profi-guarantee](http://www.wagner-group.com/profi-guarantee). The guarantee certificate is valid as confirmation, as is the original purchase document that carries the date of the purchase. Registration is only possible if the buyer is in agreement with having the data being stored that is entered during registration.

When services are carried out under guarantee the guarantee period for the product is neither extended nor renewed.

Once the guarantee period has expired, claims made against the guarantee or from the guarantee can no longer be enforced.

### 3. Handling

If defects can be seen in the materials, processing or performance of the device during the guarantee period, guarantee claims must be made immediately, or at the latest within a period of 2 weeks.

The authorised specialist shop that delivered the device is entitled to accept guarantee claims. Guarantee claims may also be made to the service centres named in our operating instructions. The product has to be sent without charge or presented together with the original purchase document that includes details of the purchase date and the name of the product. In order to claim for an extension to the guarantee, the guarantee certificate must be included.

The costs as well as the risk of loss or damage to the product in transit or by the centre that accepts the guarantee claims or who delivers the repaired product, are the responsibility of the customer.

## 4. Exclusion of guarantee

Guarantee claims cannot be considered

- for parts that are subject to wear and tear due to use or other natural wear and tear, as well as defects in the product that are a result of natural wear and tear, or wear and tear due to use. This includes in particular cables, valves, packaging, jets, cylinders, pistons, means-carrying housing components, filters, pipes, seals, rotors, stators, etc. Damage due to wear and tear that is caused in particular by sanded coating materials, such as dispersions, plaster, putty, adhesives, glazes, quartz foundation.
- in the event of errors in devices that are due to non-compliance with the operating instructions, unsuitable or unprofessional use, incorrect assembly and/or commissioning by the buyer or by a third party, or utilisation other than is intended, abnormal ambient conditions, unsuitable coating materials, unsuitable operating conditions, operation with the incorrect mains voltage supply/frequency, over-operation or defective servicing or care and/or cleaning.
- for errors in the device that have been caused by using accessory parts, additional components or spare parts that are not original Wagner parts.
- for products to which modifications or additions have been carried out.
- for products where the serial number has been removed or is illegible
- for products to which attempts at repairs have been carried out by unauthorised persons.
- for products with slight deviations from the target properties, which are negligible with regard to the value and usability of the device.
- for products that have been partially or fully taken apart.

## 5. Additional regulations.

The above guarantees apply exclusively to products that have been bought by authorised specialist shops in the EU, CIS, Australia and are used within the reference country.

If the check shows that the case is not a guarantee case, repairs are carried out at the expense of the buyer.

The above regulations manage the legal relationship to us conclusively. Additional claims, in particular for damages and losses of any type, which occur as a result of the product or its use, are excluded from the product liability act except with regard to the area of application.

Claims for liability for defects to the specialist trader remain unaffected.

German law applies to this guarantee. The contractual language is German. In the event that the meaning of the German and a foreign text of this guarantee deviate from one another, the meaning of the German text has priority.

### J. Wagner GmbH

Division Professional Finishing

Otto Lilienthal Strasse 18

88677 Markdorf

Federal Republic of Germany

### Note on disposal:

In observance of the European Directive 2002/96/EC on waste electrical and electronic equipment and implementation in accordance with national law, this product is not to be disposed of together with household waste material but must be recycled in an environmentally friendly way!

Wagner or one of our dealers will take back your used Wagner waste electrical or electronic equipment and will dispose of it for you in an environmentally friendly way. Please ask your local Wagner service centre or dealer for details or contact us direct.

